

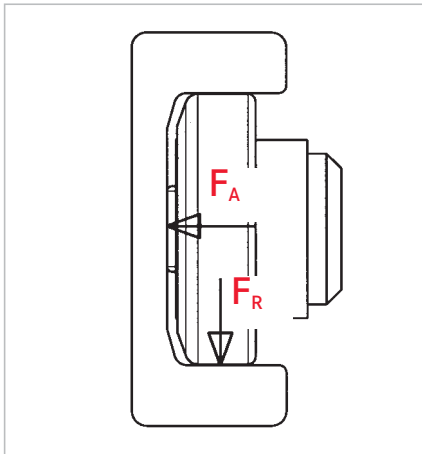

Kombirollen | Combined Bearings



S.16 Berechnung Rollenbelastung
Calculation bearing forces



S.18 Axialrollen fest (PR)
Axial Bearings fixed (PR)



S.22 Hochtemperatur-Kombirollen
High temperature Comb. Bearings



S.24 Axialrollen über Exzenter justierbar (PR)
Axial Bearings eccentric adjustable (PR)



S.28 Axialrollen über Scheiben justierbar (PR)
Axial Bearings adjustable by shims (PR)



S.32 Kombirollen mit Oilamid-Einsatz (PR)
Combined Bearings, Oilamid insert (PR)



S.36 Jumbo- Kombirollen
Jumbo Combined Bearings



S.38 Radiallager (PR)
Radial Bearings (PR)



S.42 Justierbare Kombirolleneinheit JC
Adjustable Combined Bearing Unit JC



Kombirollen | Combined Bearings



S.44 Kombirollen mit Kombibolzen (P)+(PR)
Combined Bearings+combined bolt (P)+(PR)



S.52 Profile
Profiles



S.68 Anschraubplatten
Flange plates



S.84 Kombirollen + Profile in Edelstahl
Combined Bearings + profiles in inox



S.88 VULKOLLAN Kombirollen
VULKOLLAN Combined Bearings



S.102 Profile für VULKOLLAN + POLYAMID
Kombirollen
Profiles for VULKOLLAN + POLYAMIDE
Combined Bearings

NEU
NEW

S.96 POLYAMID Kombirollen
POLYAMIDE Combined Bearings

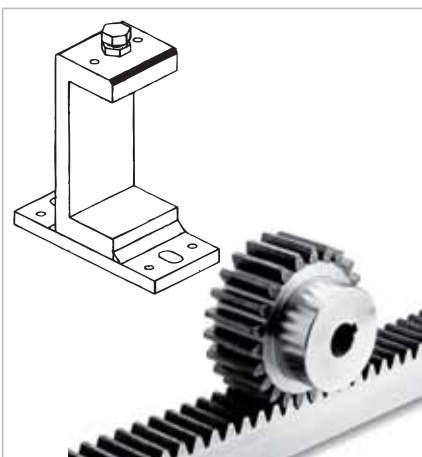

S.104 Klemmflansche/Zahnräder u. Zahnstangen
Clamp flanges/Racks and pinions



S.108 Korrosionsschutz für Lager und Profile
Corrosion protection for bearings + profiles

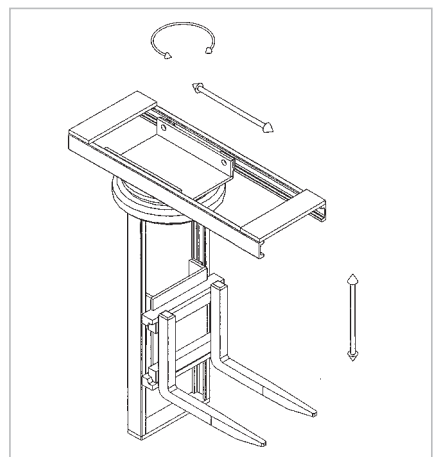

S.116 Anwendungsbeispiele / Allg. Hinweise
Application examples / General advices



Kombirollen von WINKEL

Mit unseren Kombirollen können Vertikal- und Horizontalbewegungen an Maschinen und Hubvorrichtungen wirtschaftlich gelöst werden.

Vorteile der Kombirolle:

- Das Kombirollensystem senkt Ihre Konstruktions- und Produktionskosten.
- Das Kombirollensystem kann hohe Radial- und Axialbelastungen aufnehmen.
- Starkwandige Führungsprofile für hohe stat. und dynamische Belastungen.
- Optimale Krafteinleitung in die Führungsprofile.
- Höhere Lebensdauer von Rolle und Profil.
- Montagezeitersparnis durch Einschweißbolzen.
- Lagerkomponenten sind leicht tauschbar.

Technische Daten:

- Die Außenringe sind aus Einsatzstahl UNI 16 CrNi 4 gehärtet 62+2 HRC.
- Die Innenringe sind aus Stahl DIN 100 Cr 6 gehärtet 62-2 HRC.
- Flachköpfige Rollen aus Stahl DIN 100 Cr 6 gehärtet 59 ÷ 64 HRC.
- Anschweißbolzen aus Stahl S355 J2G3 (St 52.3)
- Bolzentoleranz -0,05 mm.
- Nachschmierbarkeit für Rollen 4.055 ÷ 4.063.
- Kombirollen werden bei der Montage mit Schmierfett Grad 3 (z.B. Shell Alvania 3, Esso Beacon 3) befestigt.

WINKEL Combined Bearings

For economical designs in machines, lifting and handling systems.

Advantage of the Combined Bearing system:

- Reduces your designing and production costs.
- Can take up high radial and axial loads.
- Strong profiles for high stat. and dynamic loads.
- Best dispersion of forces in the profiles.
- Longer lifetime for bearings and profiles.
- Economical assembling by welding bolt.
- Bearing components are easily exchangeable.

Technical characteristics

- Outer rings are made from case-hardened steel UNI 16 CrNi 4 hardened at 62+2HRC.
- Inner rings are made from bearing steel En 31-SAE 52100 hardened at 62-2 HRC.
- Cylindrical rollers have flat ground heads, made from En 31-SAE 52100 steel hardened at 59 ÷ 64 HRC.
- Welding bolts are made from UNI FE 510.C.
- Bolt tolerance -0.05 mm.
- Bearings from 4.055 to 4.063 are relubricateable.
- Bearings are lubricated with grease grade 3 (e.g. Shell Alvania 3, Esso Beacon 3).





Kombirollen von WINKEL

Basierend auf einem Baukastensystem haben Sie die Möglichkeit unendlich vieler Anwendungen.

- Kombirollen
- Profile
- Klemmflansche

CAD Download in 2D/3D unter www.winkel.de

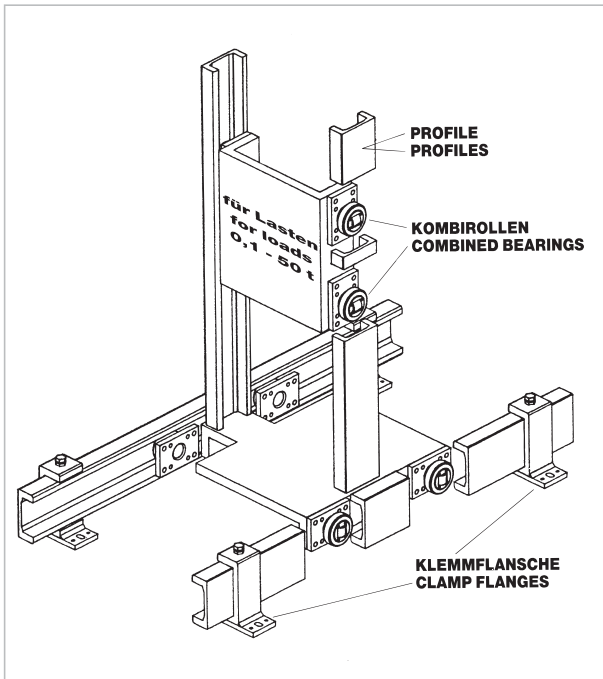

WINKEL Combined Bearings

Based on a unit construction system for various applications.

- Combined Bearings
- Profiles
- Clamp flanges

CAD download in 2D/3D at www.winkel.de





Kombirollen | Combined Bearings

Berechnung der Rollenbelastung

Q = Nutzlast (N)
 L = Lastabstand vom Aufhängepunkt (mm)
 P = Aufhängepunkt
 A = Rollenabstand (mm) empfohlen 500-1000 mm

Formel

$$F_{\text{max stat. radial}} [\text{N}] = \frac{Q \cdot L}{2 \cdot A}$$

Um Einwalzungen am nicht gehärteten Profil zu vermeiden sollte die Pressung maximal
 $P_{\text{Zul}} = 860 \text{ N/mm}^2$ für Nb-Profile (St.0-St.6 + PRO-PR6)
 $P_{\text{Zul}} = 750 \text{ N/mm}^2$ für alle restlichen Profile betragen.
 $F_{\text{max stat radial}} + \text{axial}$ sind für die jeweiligen Lager in der Tabelle angegeben.

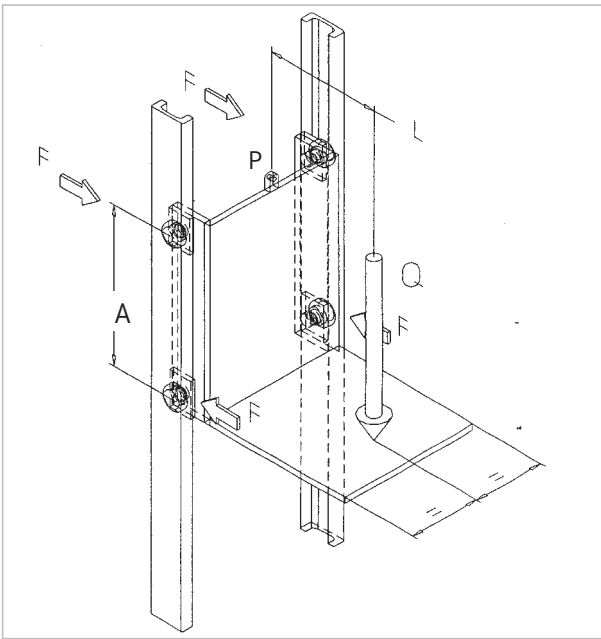

Calculation of the bearing forces

Q = Load capacity (N)
 L = Load distance to suspension point (mm)
 P = Suspension point
 A = Bearing distance (mm) recommended 500-1000 mm

Formula

$$F_{\text{max stat. radial}} [\text{N}] = \frac{Q \cdot L}{2 \cdot A}$$

To avoid wear out in the profile, which is not hardened, the pressure between bearing and profile should be max.
 $P_{\text{Zul}} = 860 \text{ N/mm}^2$ for Nb-profiles (St.0-St.6 + PRO-PR6)
 $P_{\text{Zul}} = 750 \text{ N/mm}^2$ for all profiles except Nb-series.
 Here indicated are $F_{\text{max stat radial+axial}}$ for each bearing.

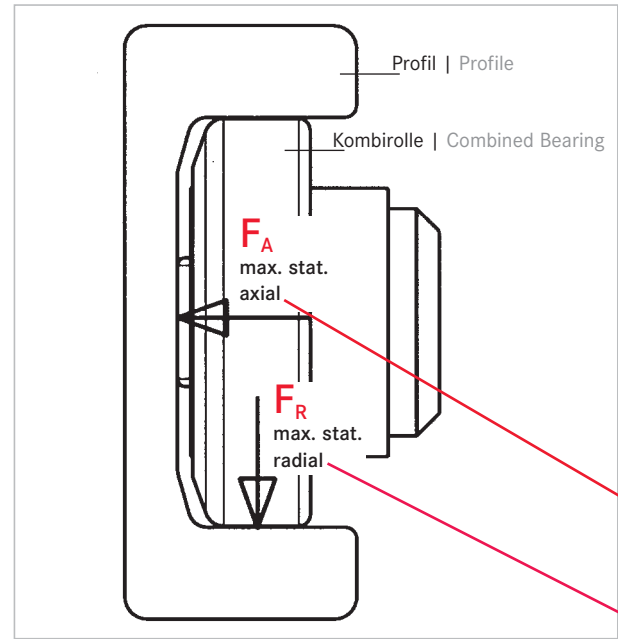

Beispiel | Example

Typ Type	D mm. D mm.	T mm. T mm.	d -0.05 mm. d -0.05 mm.	H mm. H mm.	h mm. h mm.	B mm. B mm.	A mm. A mm.	S mm. S mm.	r mm. r mm.
4.054	62,5	42	30	37,5	30,5	20	2,5	20	3
4.055	70,1	48	35	44,0	36,0	23	2,5	22	4
4.056	77,7	54	40	48,0	36,5	23	3,0	26	4
4.057	77,7	53	40	40,0	29,0	23	3,0	26	4
4.058	88,4	59	45	57,0	44,0	30	3,5	26	3
4.059	101,2	67	50	46,0	33,0	28	3,0	30	3
4.060	107,7	71	55	54,0	39,0	31	3,0	34	5
4.061	107,7	71	60	69,0	55,0	31	4,0	34	5
4.062	123,0	80	60	72,3	56,0	37	5,0	40	5
4.063	149,0	103	60	78,5	58,5	43	5,5	50	3

C = Dyn. Tragzahl Radiallager (ISO 281/1), C₀ = Stat. Tragzahl Radiallager (ISO 76),
 C_A = Dyn. Tragzahl Axiallager (ISO 281/1), C_{0A} = Stat. Tragzahl Axiallager (ISO 76),
 F_R = Tragzahl Radiallager zulässige Belastung zwischen Rolle und Profil,
 F_A = Tragzahl Axiallager zulässige Belastung zwischen Rolle und Profil



Kombirollen | Combined Bearings

Auswahl der Wälzlager über die Hertz'sche Pressung

Selection of bearings over the hertzian pressure

Radiallager	Kombirolle	Kombirolle	Kombirolle	Kombirolle mit Justierlager	Kombirolle mit Kombibolzen	F_R KN	F_A KN	Profile		
	Axialrolle fest	Axialrolle einstellbar	Axialrolle einstellbar			max. stat. radial	max. stat. axial			
Radial Bearing	Combined Bearing	Combined Bearing	Combined Bearing	Combined Bearing with adjustable bearing	Combined Bearing with combined bolt	max. stat. radial	max. stat. axial	Profiles		
	Axial Bearing fix	Axial Bearing adjustable	Axial Bearing adjustable							
-	4.052 P	-	-	-	-	0,80	0,40	A	-	-
-	4.053	-	-	-	-	5,23	1,68	S	-	-
(PR) 2.054	(PR) 4.054	(PR) 4.454	(PR) 4.072	JC 4.054	KB (PR) 4.072	9,40	3,10	0 NB	PR 0 NB	-
(PR) 2.055	(PR) 4.055	(PR) 4.455	(PR) 4.073	JC 4.055	KB (PR) 4.073	11,30 (8,59)	3,73 (2,86)	1 NB	PR 1 NB	(3018)
(PR) 2.056	(PR) 4.056	(PR) 4.456	(PR) 4.074	JC 4.056	KB (PR) 4.074	11,72	3,87	2 NB	PR 2 NB	-
-	4.057	4.457	4.075	-	-	(8,92)	(2,97)	-	-	(3019)
(PR) 2.058	(PR) 4.058	(PR) 4.458	(PR) 4.076	JC 4.058	KB (PR) 4.076	20,47 (15,57)	6,76 (5,19)	3 NB	PR 3 NB	(3020)
-	4.059	4.459	4.077	-	-	(15,47)	(5,15)	-	-	(2912)
-	4.060	4.460	4.078	-	-	(16,49)	(5,49)	-	-	(3100)
(PR) 2.061	(PR) 4.061	(PR) 4.461	(PR) 4.0784	JC 4.061	KB (PR) 4.0784	21,68	7,16	4 NB	PR 4 NB	-
(PR) 2.062	(PR) 4.062	(PR) 4.462	(PR) 4.079	JC 4.062	KB (PR) 4.079	30,92 (23,52)	10,20 (7,84)	5 NB	PR 5 NB	(3353)
(PR) 2.063	(PR) 4.063	(PR) 4.463	-	JC 4.063	-	54,02	17,80	6 NB	PR 6 NB	-
-	-	-	(PR) 4.080	-	KB (PR) 4.080	37,81	17,80	6 NB	PR 6 NB	-
-	-	(PR) 4.085	-	-	-	64,70	19,40	8 NB	PR 8 NB	-
-	-	4.089	-	-	-	41,71	13,91	10	-	-
-	-	4.090	-	-	-	58,00	19,40	16	-	-
-	-	4.091	-	-	-	84,00	28,00	18	-	-
-	-	4.092	-	-	-	101,50	33,90	28	-	-
-	-	4.093	-	-	-	139,40	46,50	36	42	-

Typ	F_R KN	F_A KN	C KN	C ₀ KN	C _A KN	C _{0A} KN	u/min max.	Gewicht kg	Anschraubplatten		Profile Standard
Type	F_R KN	F_A KN	C KN	C ₀ KN	C _A KN	C _{0A} KN	r/pm max.	Weight kg	Flange plates		Profiles standard
4.054	9,40	3,10	31,0	35,5	11	11	900	0,53	AP0	AP0-Q	0 Nb
4.055	11,30 (8,59)	3,73 (2,86)	45,5	51,0	13	14	900	0,80	AP1	AP1-Q	1 Nb (3018)
4.056	11,72	3,87	48,0	56,8	18	18	800	1,00	AP2	AP2-Q	2 Nb
4.057	(8,92)	(2,97)	48,0	56,8	18	18	800	0,87	-	-	(3019)
4.058	20,47 (15,57)	6,76 (5,19)	68,0	72,0	23	23	750	1,62	AP3.1	AP3	3 Nb (3020)
4.059	(15,47)	(5,15)	73,0	82,0	25	27	700	1,74	-	-	(2912)
4.060	(16,49)	(5,49)	81,0	95,0	31	36	650	2,27	-	-	(3100)
4.061	21,68	7,16	81,0	95,0	31	36	650	2,82	AP4	AP4-Q	4 Nb
4.062	30,92 (23,52)	10,20 (7,84)	110,0	132,0	43	50	550	3,89	AP4	AP4-Q	5 Nb (3353)
4.063	54,02	17,80	151,0	192,0	68	71	450	6,52	AP6	AP6-Q	6 Nb

C = Dynamic load capacity radial bearing (ISO 281/1), C₀ = Static load capacity radial bearing (ISO 76),
 C_A = Dynamic load capacity axial bearing (ISO 281/1), C_{0A} = Static load capacity axial bearing (ISO 76),
 F_R = Load capacity radial bearing max. allowable force between bearing and profile,
 F_A = Load capacity axial bearing max. allowable force between bearing and profile



Axialrolle fest

Nachschmierbarkeit für Rollen 4.054 - 4.063



Abdichtung 2 RS | Sealings 2 RS

Axial Bearing fixed

Relubrication for types 4.054 - 4.063

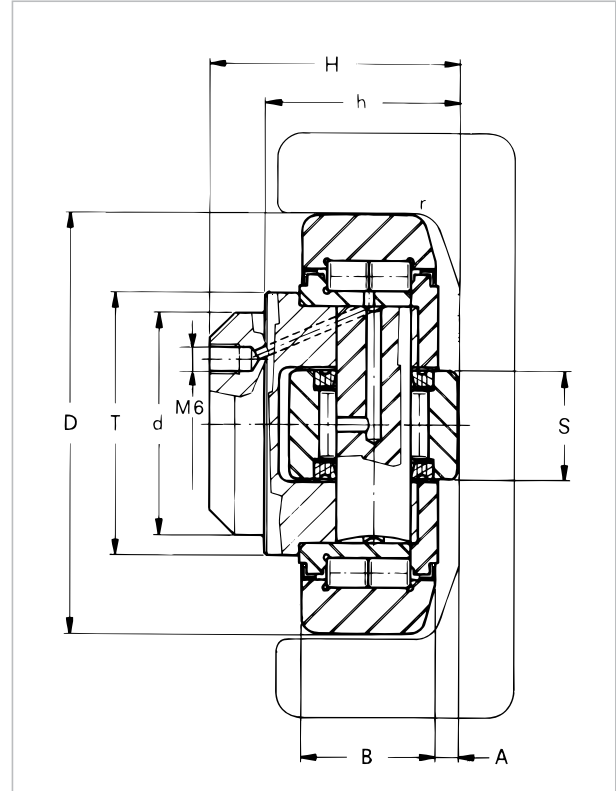

CAD Download in 2D/3D unter www.winkel.de

CAD download in 2D/3D at www.winkel.de

Bestellbeispiel | Order example

4.054 [Kombirolle]
4.054 [Combined Bearing]

AP 0 [Anschraubplatte]
AP 0 [Flange plate]

DS-0-0,5 [Distanzscheibe]
DS-0-0,5 [Washers type DS]

0 Nb [Profil]
0 Nb [Profile]

Typ Type	D mm. D mm.	T mm. T mm.	d -0.05 mm. d -0.05 mm.	H mm. H mm.	h mm. h mm.	B mm. B mm.	A mm. A mm.	S mm. S mm.	r mm. r mm.
4.053	52,5	40	30	33,0	27,0	17	5,0	15	2
4.054	62,5	42	30	37,5	30,5	20	2,5	20	3
4.055	70,1	48	35	44,0	36,0	23	2,5	22	4
4.056	77,7	54	40	48,0	36,5	23	3,0	26	4
4.057	77,7	53	40	40,0	29,0	23	3,0	26	4
4.058	88,4	59	45	57,0	44,0	30	3,5	26	3
4.059	101,2	67	50	46,0	33,0	28	3,0	30	3
4.060	107,7	71	55	54,0	39,0	31	3,0	34	5
4.061	107,7	71	60	69,0	55,0	31	4,0	34	5
4.062	123,0	80	60	72,3	56,0	37	5,0	40	5
4.063	149,0	103	60	78,5	58,5	43	5,5	50	3

C = Dyn. Tragzahl Radiallager (ISO 281/1), C₀ = Stat. Tragzahl Radiallager (ISO 76),
C_A = Dyn. Tragzahl Axiallager (ISO 281/1), C_{0A} = Stat. Tragzahl Axiallager (ISO 76),
F_R = Tragzahl Radiallager zulässige Belastung zwischen Rolle und Profil,
F_A = Tragzahl Axiallager zulässige Belastung zwischen Rolle und Profil



Passende Anschraubplatten

Fitting flange plates

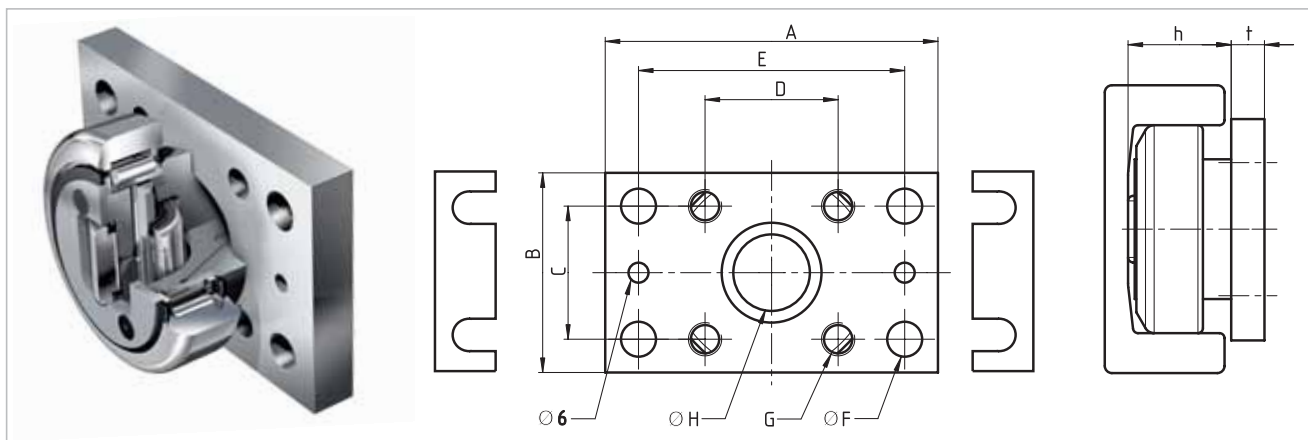

Typ Type	A	B	C	D	E	Ø F Ø F	G	Ø H Ø H	t	Distanzscheibe t=0,5mm Washer t=0.5mm	Distanzscheibe t=1,0mm Washer t=1.0mm
AP S	90	50	30	40	70	8,5	M8	30	10	DS-S-0,5	DS-S-1,0
AP 0	100	60	40	40	80	10,5	M10	30	10	DS-0-0,5	DS-0-1,0
AP 1	120	80	50	50	90	12,5	M12	35	15	DS-1-0,5	DS-1-1,0
AP 2	120	80	50	50	90	12,5	M12	40	15	DS-2-0,5	DS-2-1,0
AP 3.1	160	100	60	60	120	17,0	M16	45	20	DS-3.1-0,5	DS-3.1-1,0
AP 4	180	120	80	80	140	17,0	M16	60	20	DS-4-0,5	DS-4-1,0
AP 6	200	150	100	100	160	17,0	M16	60	20	DS-6-0,5	DS-6-1,0

Anschraubplatten quadratisch Reihe AP-Q S. 74
Flange plates square series AP-Q page 74

Profile S. 52
Profiles page 52

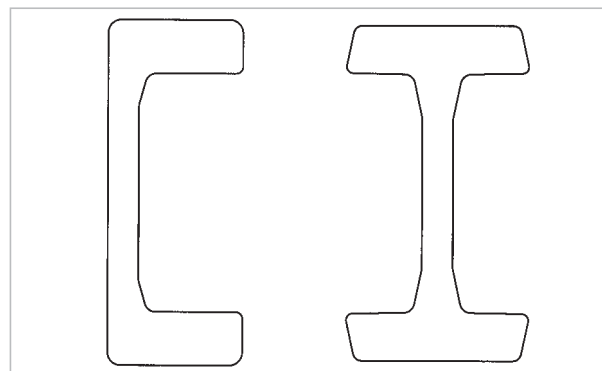
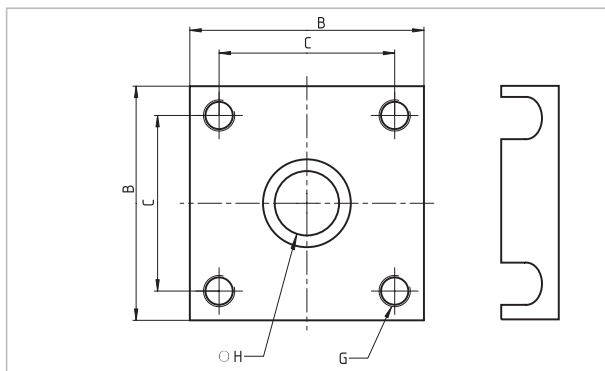

Typ Type	F _R KN F _R KN	F _A KN F _A KN	C KN C KN	C ₀ KN C ₀ KN	C _A KN C _A KN	C _{0A} KN C _{0A} KN	u/min max. r/pm max.	Gewicht kg Weight kg	Anschraubplatten Flange plates	Profile Standard Profiles standard
4.053	5,23	1,68	24,0	32,0	7	7	800	0,46	APS	S
4.054	9,40	3,10	31,0	35,5	11	11	900	0,53	AP0 AP0-Q	0 Nb
4.055	11,30 (8,59)	3,73 (2,86)	45,5	51,0	13	14	900	0,80	AP1 AP1-Q	1 Nb (3018)
4.056	11,72	3,87	48,0	56,8	18	18	800	1,00	AP2 AP2-Q	2 Nb
4.057	(8,92)	(2,97)	48,0	56,8	18	18	800	0,87	-	(3019)
4.058	20,47 (15,57)	6,76 (5,19)	68,0	72,0	23	23	750	1,62	AP3.1 AP3	3 Nb (3020)
4.059	(15,47)	(5,15)	73,0	82,0	25	27	700	1,74	-	(2912)
4.060	(16,49)	(5,49)	81,0	95,0	31	36	650	2,27	-	(3100)
4.061	21,68	7,16	81,0	95,0	31	36	650	2,82	AP4 AP4-Q	4 Nb
4.062	30,92 (23,52)	10,20 (7,84)	110,0	132,0	43	50	550	3,89	AP4 AP4-Q	5 Nb (3353)
4.063	54,02	17,80	151,0	192,0	68	71	450	6,52	AP6 AP6-Q	6 Nb

C = Dynamic load capacity radial bearing (ISO 281/1), C₀ = Static load capacity radial bearing (ISO 76),
C_A = Dynamic load capacity axial bearing (ISO 281/1), C_{0A} = Static load capacity axial bearing (ISO 76),
F_R = Load capacity radial bearing max. allowable force between bearing and profile,
F_A = Load capacity axial bearing max. allowable force between bearing and profile



Kombirollen | Combined Bearings

Präzisions-Kombirolle

Typ PR

Axialrolle fest

Vorteil:

- weniger Spiel zwischen Rolle und Profil

Nachschmierbarkeit nur für Rollen PR 4.055 - PR 4.063

Precision Combined Bearing

Type PR

Axial Bearing fixed

Advantage:

- less clearance between bearing and profile

Relubrication only for types PR 4.055 - PR 4.063

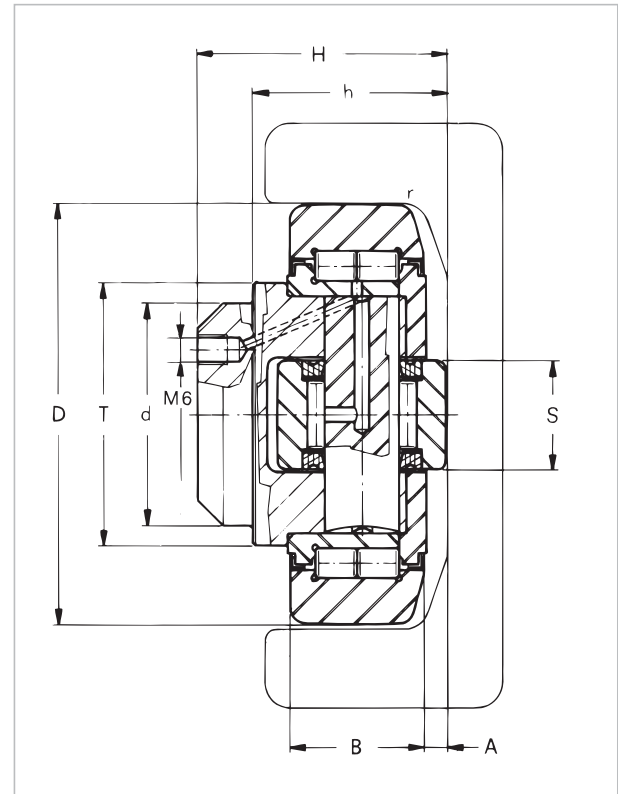

Bestellbeispiel | Order example

PR 4.054 [Kombirolle]
PR 4.054 [Combined Bearing]

AP 0 [Anschraubplatte]
AP 0 [Flange plate]

DS-0-0,5 [Distanzscheibe]
DS-0-0,5 [Washer type DS]

PR 0 Nb [Profil]
PR 0 Nb [Profile]

Typ Type	D mm. D mm.	T mm. T mm.	d -0.05 mm. d -0.05 mm.	H mm. H mm.	h mm. h mm.	B mm. B mm.	A mm. A mm.	S mm. S mm.	r mm. r mm.
PR 4.054	64,8	42	30	37,5	30,5	20	2,5	20	3
PR 4.055	73,8	48	35	44,0	36,0	23	2,5	22	4
PR 4.056	81,8	54	40	48,0	36,5	23	3,0	26	4
PR 4.058	92,8	59	45	57,0	44,0	30	3,5	26	3
PR 4.061	111,8	71	60	69,0	55,0	31	4,0	34	5
PR 4.062	127,8	80	60	72,3	56,0	37	5,0	40	5
PR 4.063	153,8	103	60	78,5	58,5	43	5,5	50	3

C = Dyn. Tragzahl Radiallager (ISO 281/1), C₀ = Stat. Tragzahl Radiallager (ISO 76),
C_A = Dyn. Tragzahl Axiallager (ISO 281/1), C_{0A} = Stat. Tragzahl Axiallager (ISO 76),
F_R = Tragzahl Radiallager zulässige Belastung zwischen Rolle und Profil,
F_A = Tragzahl Axiallager zulässige Belastung zwischen Rolle und Profil



Passende Anschraubplatten

Fitting flange plates

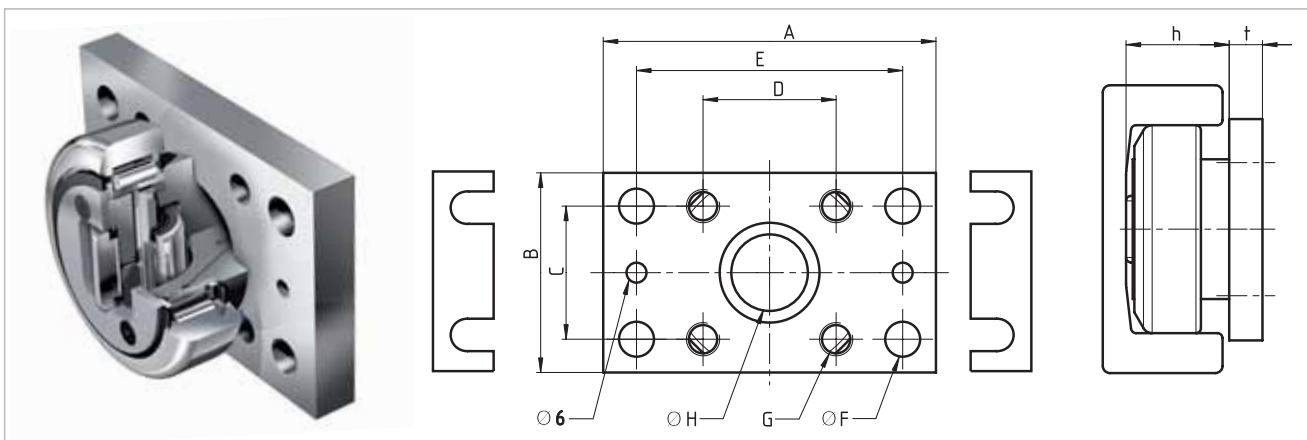

Typ Type	A	B	C	D	E	Ø F	G	Ø H	t	Distanzscheibe t=0,5mm Washer t=0.5mm	Distanzscheibe t=1,0mm Washer t=1.0mm
AP 0	100	60	40	40	80	10,5	M10	30	10	DS-0-0,5	DS-0-1,0
AP 1	120	80	50	50	90	12,5	M12	35	15	DS-1-0,5	DS-1-1,0
AP 2	120	80	50	50	90	12,5	M12	40	15	DS-2-0,5	DS-2-1,0
AP 3.1	160	100	60	60	120	17,0	M16	45	20	DS-3.1-0,5	DS-3.1-1,0
AP 4	180	120	80	80	140	17,0	M16	60	20	DS-4-0,5	DS-4-1,0
AP 6	200	150	100	100	160	17,0	M16	60	20	DS-6-0,5	DS-6-1,0

Anschraubplatten quadratisch Reihe AP-Q S. 74
Flange plates square series AP-Q page 74

Profile S. 56
Profiles page 56

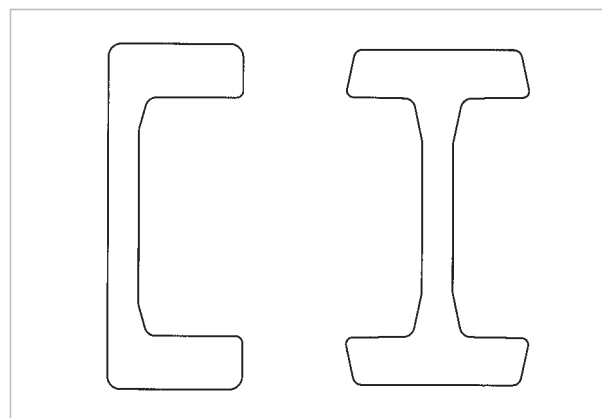
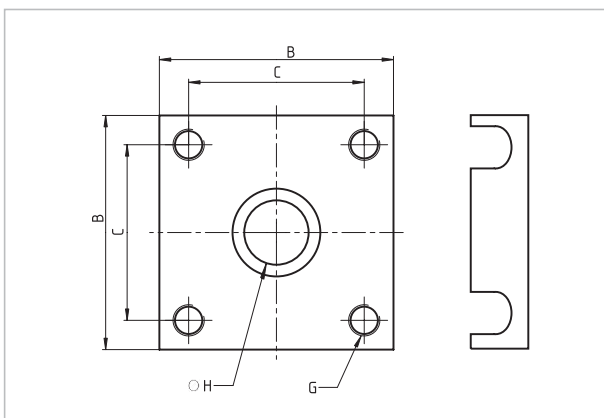

Typ Type	F _R KN F _R KN	F _A KN F _A KN	C KN C KN	C ₀ KN C ₀ KN	C _A KN C _A KN	C _{0A} KN C _{0A} KN	u/min max. r/pm max.	Gewicht kg Weight kg	Anschraubplatten Flange plates	Profile Profiles
PR 4.054	9,40	3,10	31,0	35,5	11	11	900	0,55	AP0 AP0-Q	PR 0 Nb
PR 4.055	11,30	3,73	45,5	51,0	13	14	900	0,85	AP1 AP1-Q	PR 1 Nb
PR 4.056	11,72	3,87	48,0	56,8	18	18	800	1,10	AP2 AP2-Q	PR 2 Nb
PR 4.058	20,47	6,76	68,0	72,0	23	23	750	1,70	AP3.1 AP3	PR 3 Nb
PR 4.061	21,68	7,16	81,0	95,0	31	36	650	2,95	AP4 AP4-Q	PR 4 Nb
PR 4.062	30,92	10,20	110,0	132,0	43	50	550	4,10	AP4 AP4-Q	PR 5 Nb
PR 4.063	54,02	17,80	151,0	192,0	68	71	450	6,85	AP6 AP6-Q	PR 6 Nb

C = Dynamic load capacity radial bearing (ISO 281/1), C₀ = Static load capacity radial bearing (ISO 76),
 C_A = Dynamic load capacity axial bearing (ISO 281/1), C_{0A} = Static load capacity axial bearing (ISO 76),
 F_R = Load capacity radial bearing max. allowable force between bearing and profile,
 F_A = Load capacity axial bearing max. allowable force between bearing and profile



Kombirollen | Combined Bearings

Hochtemperatur-Kombirolle
Typ HT

- Kombirollen der Baureihe HT in Hochtemperaturausführung sind geeignet für Einsatztemperaturen bis 250°C.
- Die Kombirollen verfügen über Lagerluft C3, Hochtemperaturfett sowie Metaldichtungen.
- Nachschmierbarkeit nur für Rollen 4.055 HT - 4.063 HT.



High temperature Combined Bearing
Type HT

- Combined Bearings of range HT are made for high temperature applications up to 250°C.
- The Combined Bearings are made with tolerance C3, high temperature grease and metal sealings.
- Relubrication only for types 4.055 HT - 4.063 HT.

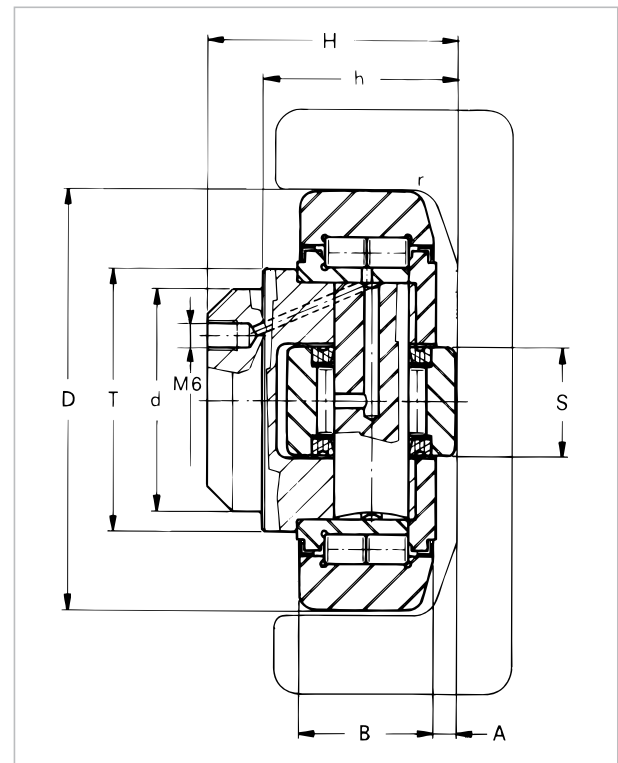

Bestellbeispiel | Order example

4.054 HT [Kombirolle] AP 0 [Anschraubplatte] DS-0-0,5 [Distanzscheibe] 0 Nb [Profil]
 4.054 HT [Combined Bearing] AP 0 [Flange plate] DS-0-0,5 [Washers type DS] 0 Nb [Profile]

CAD Download in 2D/3D unter www.winkel.de

CAD download in 2D/3D at www.winkel.de

Typ Type	D mm. D mm.	T mm. T mm.	d -0.05 mm. d -0.05 mm.	H mm. H mm.	h mm. h mm.	B mm. B mm.	A mm. A mm.	S mm. S mm.	r mm. r mm.
4.053 HT	52,5	40	30	33,0	27,0	17	5,0	15	2
4.054 HT	62,5	42	30	37,5	30,5	20	2,5	20	3
4.055 HT	70,1	48	35	44,0	36,0	23	2,5	22	4
4.056 HT	77,7	54	40	48,0	36,5	23	3,0	26	4
4.058 HT	88,4	59	45	57,0	44,0	30	3,5	26	3
4.061 HT	107,7	71	60	69,0	55,0	31	4,0	34	5
4.062 HT	123,0	80	60	72,3	56,0	37	5,0	40	5
4.063 HT	149,0	103	60	78,5	58,5	43	5,5	50	3

C = Dyn. Tragzahl Radiallager (ISO 281/1), C₀ = Stat. Tragzahl Radiallager (ISO 76),
 C_A = Dyn. Tragzahl Axiallager (ISO 281/1), C_{0A} = Stat. Tragzahl Axiallager (ISO 76),
 F_R = Tragzahl Radiallager zulässige Belastung zwischen Rolle und Profil,
 F_A = Tragzahl Axiallager zulässige Belastung zwischen Rolle und Profil



Passende Anschraubplatten

Fitting flange plates

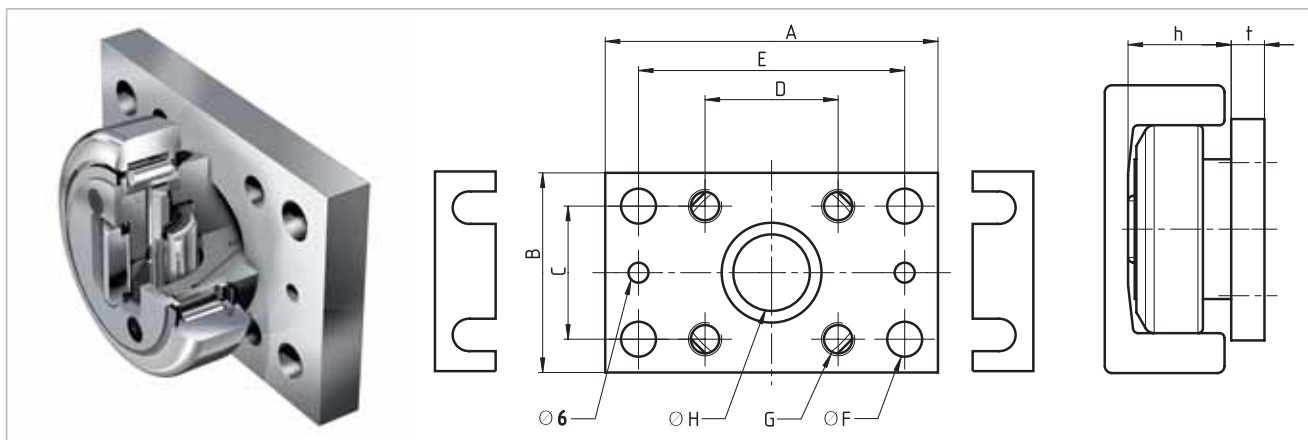

Typ Type	A	B	C	D	E	Ø F Ø F	G	Ø H Ø H	t	Distanzscheibe t=0,5mm Washer t=0.5mm	Distanzscheibe t=1,0mm Washer t=1.0mm
AP S	90	50	30	40	70	8,5	M8	30	10	DS-S-0,5	DS-S-1,0
AP 0	100	60	40	40	80	10,5	M10	30	10	DS-0-0,5	DS-0-1,0
AP 1	120	80	50	50	90	12,5	M12	35	15	DS-1-0,5	DS-1-1,0
AP 2	120	80	50	50	90	12,5	M12	40	15	DS-2-0,5	DS-2-1,0
AP 3.1	160	100	60	60	120	17,0	M16	45	20	DS-3.1-0,5	DS-3.1-1,0
AP 4	180	120	80	80	140	17,0	M16	60	20	DS-4-0,5	DS-4-1,0
AP 6	200	150	100	100	160	17,0	M16	60	20	DS-6-0,5	DS-6-1,0

Anschraubplatten quadratisch Reihe AP-Q S. 74
Flange plates square series AP-Q page 74

Profile S. 52
Profiles page 52

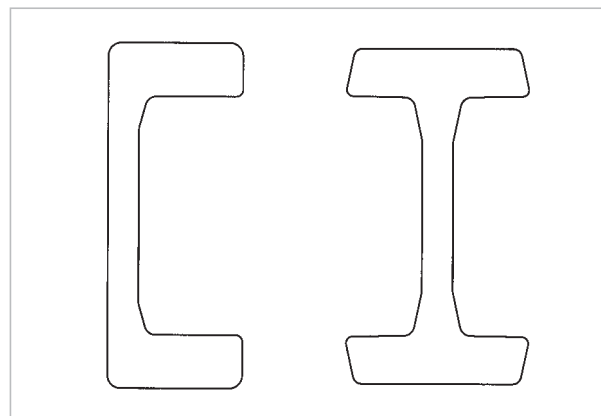
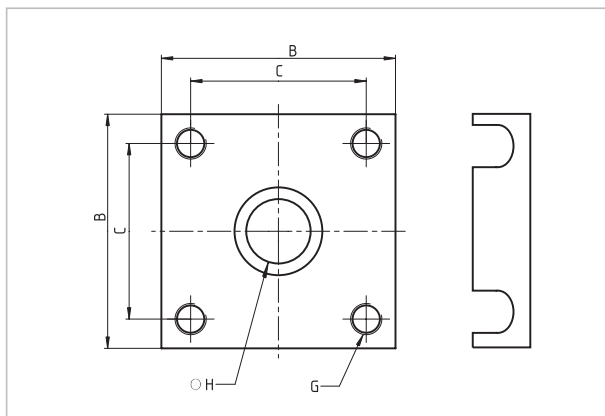

Typ Type	F _R KN F _R KN	F _A KN F _A KN	C KN C KN	C ₀ KN C ₀ KN	C _A KN C _A KN	C _{0A} KN C _{0A} KN	u/min max. r/pm max.	Gewicht kg Weight kg	Anschraubplatten Flange plates	Profile Profiles
4.053 HT	5,23	1,68	24,0	32,0	7	7	800	0,46	APS	S
4.054 HT	9,40	3,10	31,0	35,5	11	11	900	0,55	AP0 AP0-Q	0 Nb
4.055 HT	11,30 (8,59)	3,73 (2,86)	45,5	51,0	13	14	900	0,85	AP1 AP1-Q	1 Nb (3018)
4.056 HT	11,72	3,87	48,0	56,8	18	18	800	1,10	AP2 AP2-Q	2 Nb
4.058 HT	20,47 (15,57)	6,76 (5,19)	68,0	72,0	23	23	750	1,70	AP3.1 AP3	3 Nb (3020)
4.061 HT	21,68	7,16	81,0	95,0	31	36	650	2,95	AP4 AP4-Q	4 Nb
4.062 HT	30,92 (23,52)	10,20 (7,84)	110,0	132,0	43	50	550	4,10	AP4 AP4-Q	5 Nb (3353)
4.063 HT	54,02	17,80	151,0	192,0	68	71	450	6,85	AP6 AP6-Q	6 Nb

C = Dynamic load capacity radial bearing (ISO 281/1), C₀ = Static load capacity radial bearing (ISO 76),
C_A = Dynamic load capacity axial bearing (ISO 281/1), C_{0A} = Static load capacity axial bearing (ISO 76),
F_R = Load capacity radial bearing max. allowable force between bearing and profile,
F_A = Load capacity axial bearing max. allowable force between bearing and profile



Axialrolle über Exzenter justierbar

■ Rollen lebensdauergeschmiert



Abdichtung 2 RS | Sealings 2 RS

Axial Bearing eccentric adjustable

■ bearings are lubricated for life

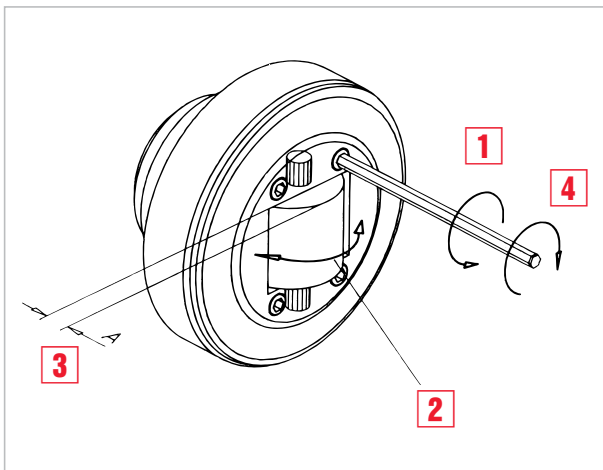
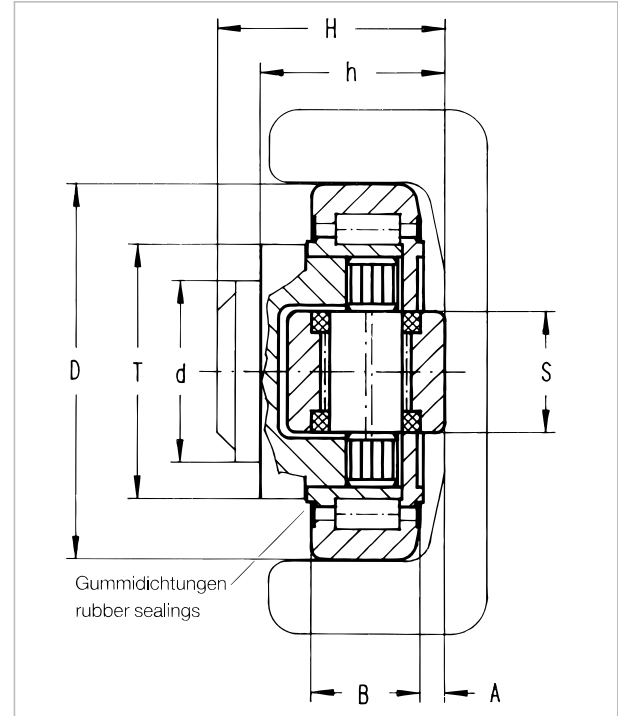

CAD Download in 2D/3D unter www.winkel.de

Justierung der Axialrolle

- 1 Deckelschrauben lösen
- 2 Exzenterachse drehen (Axialrolle wird verdreht)
- 3 Maß A überprüfen (ggf. Punkt 2 wiederholen)
- 4 Schrauben mit Loctite sichern
- 5 Deckelschrauben festziehen

Adjusting of the Axial Bearing

- 1 loosen screws
- 2 turn eccentric axle (Axial Bearing will be turned)
- 3 check measure A (if necessary repeat Pos.2)
- 4 secure screws with loctite
- 5 lock screws

CAD download in 2D/3D at www.winkel.de

Typ Type	D mm. D mm.	T mm. T mm.	d -0.05 mm. d -0.05 mm.	H mm. H mm.	h mm. h mm.	B mm. B mm.	A mm. A mm.	S mm. S mm.	r mm. r mm.
4.454	62,5	42	30	37,5 - 39,0	30,5 - 32,0	20	4,0 - 5,5	20	3
4.455	70,1	48	35	44,0 - 45,5	36,0 - 37,5	23	4,0 - 5,5	20	4
4.456	77,7	54	40	48,0 - 49,5	37,0 - 38,5	23	3,5 - 5,0	26	4
4.457	78,3	54	40	40,0 - 41,5	29,0 - 30,5	23	3,5 - 5,0	26	4
4.458	88,4	59	45	57,0 - 58,5	44,0 - 45,5	30	4,0 - 5,5	26	4
4.459	101,6	69	50	46,0 - 48,0	33,0 - 35,0	26	4,5 - 6,5	30	3
4.460	108,5	69	55	54,0 - 56,0	40,0 - 42,0	31	4,0 - 6,0	30	5
4.461	107,7	69	60	69,0 - 71,0	55,0 - 57,0	31	4,0 - 6,0	30	5
4.462	123,0	80	60	72,3 - 76,3	56,0 - 60,0	37	5,0 - 9,0	34	5
4.463	149,4	108	60	78,5 - 82,5	58,5 - 62,5	45	6,0 - 10,0	34	3

C = Dyn. Tragzahl Radiallager (ISO 281/1), C₀ = Stat. Tragzahl Radiallager (ISO 76),
 C_A = Dyn. Tragzahl Axiallager (ISO 281/1), C_{0A} = Stat. Tragzahl Axiallager (ISO 76),
 F_R = Tragzahl Radiallager zulässige Belastung zwischen Rolle und Profil,
 F_A = Tragzahl Axiallager zulässige Belastung zwischen Rolle und Profil



Passende Anschraubplatten

Fitting flange plates

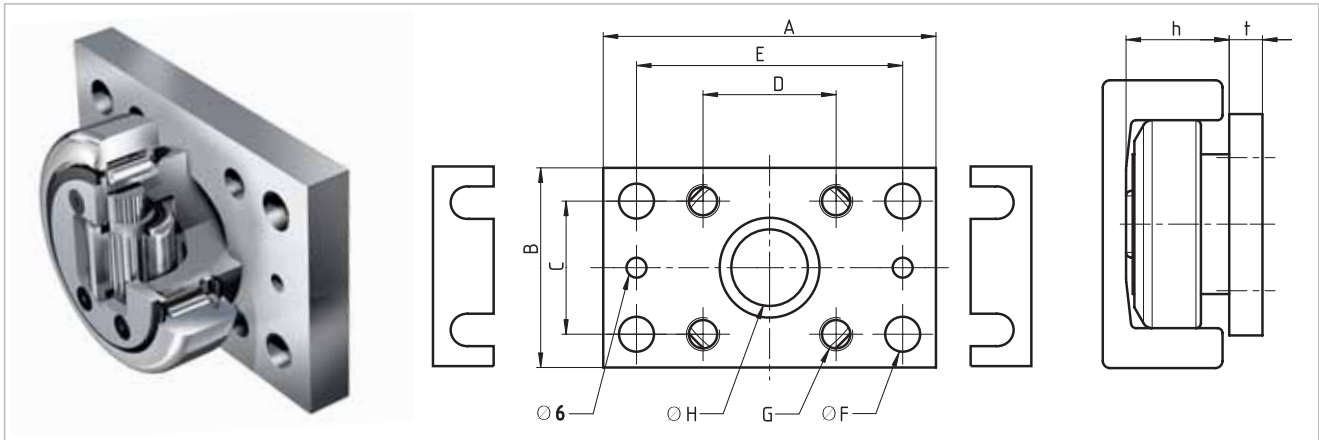

Type	A	B	C	D	E	Ø F	G	Ø H	t	Distanzscheibe t=0,5mm Washer t=0.5mm	Distanzscheibe t=1,0mm Washer t=1.0mm
AP 0	100	60	40	40	80	10,5	M10	30	10	DS-0-0,5	DS-0-1,0
AP 1	120	80	50	50	90	12,5	M12	35	15	DS-1-0,5	DS-1-1,0
AP 2	120	80	50	50	90	12,5	M12	40	15	DS-2-0,5	DS-2-1,0
AP 3.1	160	100	60	60	120	17,0	M16	45	20	DS-3.1-0,5	DS-3.1-1,0
AP 4	180	120	80	80	140	17,0	M16	60	20	DS-4-0,5	DS-4-1,0
AP 6	200	150	100	100	160	17,0	M16	60	20	DS-6-0,5	DS-6-1,0

Anschraubplatten quadratisch Reihe AP-Q S. 74
Flange plates square series AP-Q page 74

Profile S. 52
Profiles page 52

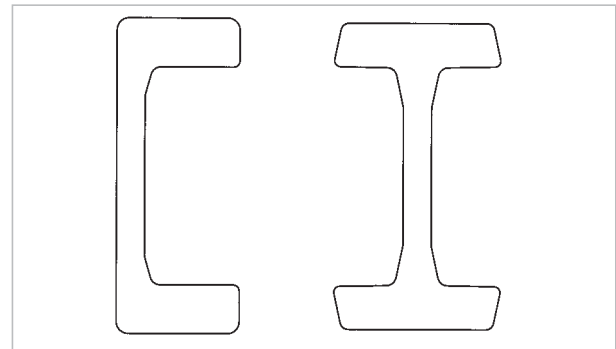
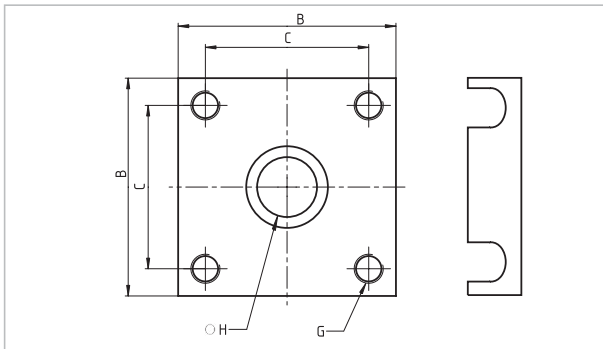

Bestellbeispiel | Order example

4.454 [Kombirolle]
4.454 [Combined Bearing]

AP 0 [Anschraubplatte]
AP 0 [Flange plate]

DS-0-0,5 [Distanzscheibe]
DS-0-0,5 [Washer type DS]

0 Nb [Profil]
0 Nb [Profile]

Type	F _R KN F _R KN	F _A KN F _A KN	C KN C KN	C _o KN C _o KN	C _A KN C _A KN	C _{oA} KN C _{oA} KN	u/min max. r/pm max.	Gewicht kg Weight kg	Anschraubplatten Flange plates	Profile Standard Profiles standard
4.454	9,40	3,10	31,0	35,5	11	11	900	0,53	AP0 AP0-Q	0 Nb
4.455	11,30 (8,59)	3,73 (2,86)	45,5	51,0	11	11	900	0,80	AP1 AP1-Q	1 Nb (3018)
4.456	11,72	3,87	48,0	56,8	18	18	800	1,00	AP2 AP2-Q	2 Nb
4.457	(8,92)	(2,97)	48,0	56,8	18	18	800	0,87	-	(3019)
4.458	20,47 (15,57)	6,76 (5,19)	68,0	72,0	23	23	750	1,62	AP3.1 AP3	3 Nb (3020)
4.459	(15,47)	(5,15)	73,0	82,0	25	27	700	1,74	-	(2912)
4.460	(16,49)	(5,49)	81,0	95,0	25	27	650	2,27	-	(3100)
4.461	21,68	7,16	81,0	95,0	25	27	650	2,82	AP4 AP4-Q	4 Nb
4.462	30,92 (23,52)	10,20 (7,84)	110,0	132,0	31	36	550	3,60	AP4 AP4-Q	5 Nb (3353)
4.463	54,02	17,80	151,0	192,0	31	36	450	6,30	AP6 AP6-Q	6 Nb

C = Dynamic load capacity radial bearing (ISO 281/1), C_o = Static load capacity radial bearing (ISO 76),
C_A = Dynamic load capacity axial bearing (ISO 281/1), C_{oA} = Static load capacity axial bearing (ISO 76),
F_R = Load capacity radial bearing max. allowable force between bearing and profile,
F_A = Load capacity axial bearing max. allowable force between bearing and profile



Kombirollen | Combined Bearings

Präzisions-Kombirolle
 Typ PR
 Axialrolle über Exzenter justierbar

Vorteil:

- weniger Spiel zwischen Rolle und Profil
- Rollen lebensdauer geschmiert



Precision Combined Bearing
 Type PR
 Axial bearing eccentric adjustable

Advantage:

- less clearance between bearing and profile
- bearings are lubricated for life

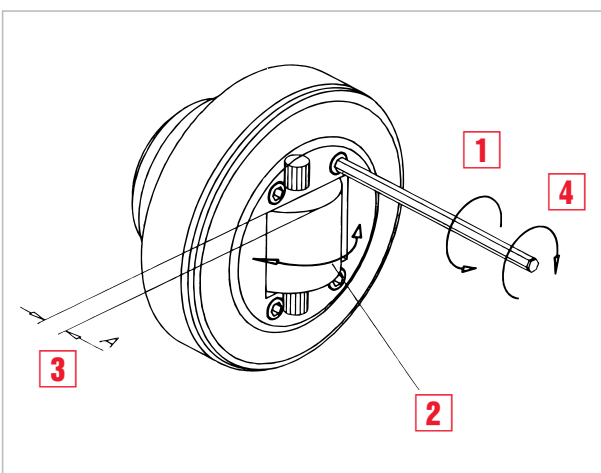
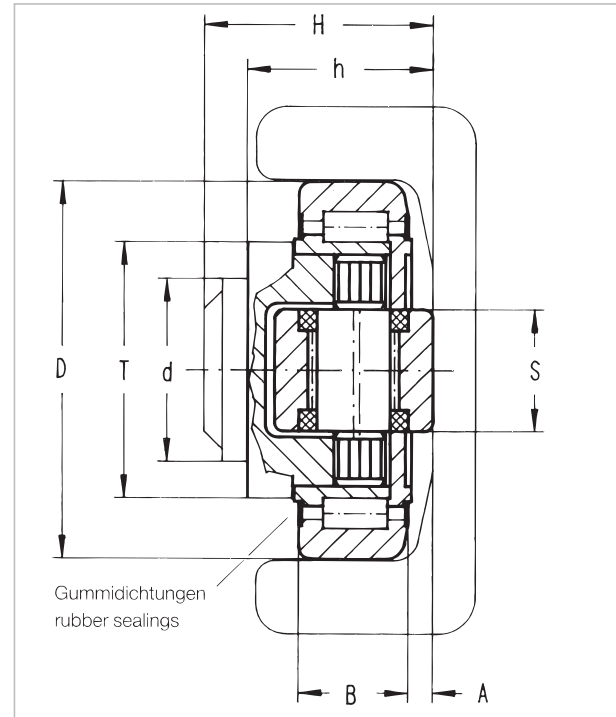

Justierung der Axialrolle

- 1 Deckelschrauben lösen
- 2 Exzenterachse drehen (Axialrolle wird verdreht)
- 3 Maß A überprüfen (ggf. Punkt 2 wiederholen)
- 4 Schrauben mit Loctite sichern
- 5 Deckelschrauben festziehen

Adjusting of the Axial Bearing

- 1 loosen screws
- 2 turn eccentric axle (Axial Bearing will be turned)
- 3 check measure A (if necessary repeat Pos.2)
- 4 secure screws with loctite
- 5 lock screws

Typ Type	D mm. D mm.	T mm. T mm.	d -0.05 mm. d -0.05 mm.	H mm. H mm.	h mm. h mm.	B mm. B mm.	A mm. A mm.	S mm. S mm.	r mm. r mm.
PR 4.454	64,8	42	30	37,5 - 39,0	30,5 - 32,0	20	4,0 - 5,5	20	3
PR 4.455	73,8	48	35	44,0 - 45,5	36,0 - 37,5	23	4,0 - 5,5	20	4
PR 4.456	81,8	54	40	48,0 - 49,5	37,0 - 38,5	23	3,5 - 5,0	26	4
PR 4.458	92,8	59	45	57,0 - 58,5	44,0 - 45,5	30	4,0 - 5,5	26	4
PR 4.461	111,8	69	60	69,0 - 71,0	55,0 - 57,0	31	4,0 - 6,0	30	5
PR 4.462	127,8	80	60	72,3 - 76,3	56,0 - 60,0	37	5,0 - 9,0	34	5
PR 4.463	153,8	108	60	78,5 - 82,5	58,5 - 62,5	45	6,0 - 10,0	34	3

C = Dyn. Tragzahl Radiallager (ISO 281/1), C₀ = Stat. Tragzahl Radiallager (ISO 76),
 C_A = Dyn. Tragzahl Axiallager (ISO 281/1), C_{0A} = Stat. Tragzahl Axiallager (ISO 76),
 F_R = Tragzahl Radiallager zulässige Belastung zwischen Rolle und Profil,
 F_A = Tragzahl Axiallager zulässige Belastung zwischen Rolle und Profil



Passende Anschraubplatten

Fitting flange plates

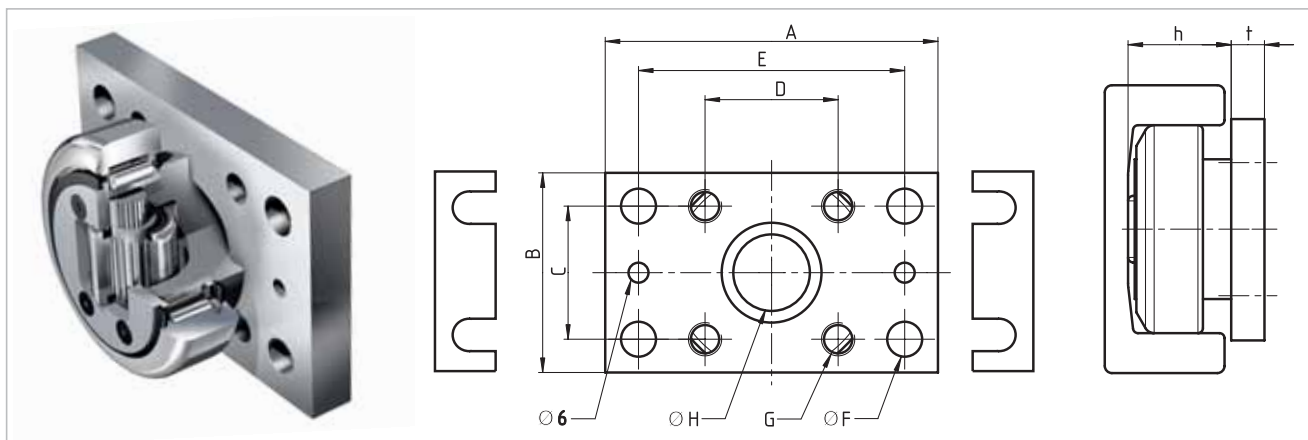

Typ Type	A	B	C	D	E	Ø F	G	Ø H	t	Distanzscheibe t=0,5mm Washer t=0.5mm	Distanzscheibe t=1,0mm Washer t=1.0mm
AP 0	100	60	40	40	80	10,5	M10	30	10	DS-0-0,5	DS-0-1,0
AP 1	120	80	50	50	90	12,5	M12	35	15	DS-1-0,5	DS-1-1,0
AP 2	120	80	50	50	90	12,5	M12	40	15	DS-2-0,5	DS-2-1,0
AP 3.1	160	100	60	60	120	17,0	M16	45	20	DS-3.1-0,5	DS-3.1-1,0
AP 4	180	120	80	80	140	17,0	M16	60	20	DS-4-0,5	DS-4-1,0
AP 6	200	150	100	100	160	17,0	M16	60	20	DS-6-0,5	DS-6-1,0

Anschraubplatten quadratisch Reihe AP-Q S. 74
Flange plates square series AP-Q page 74

Profile S. 56
Profiles page 56

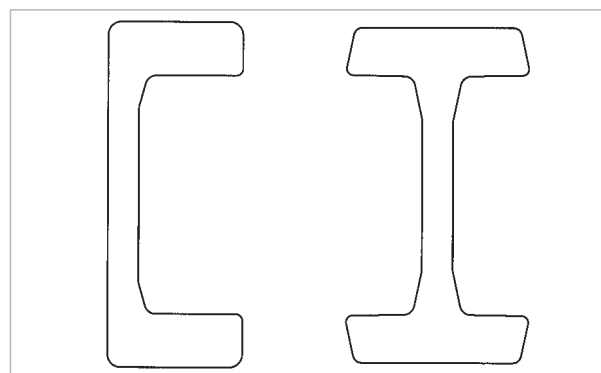
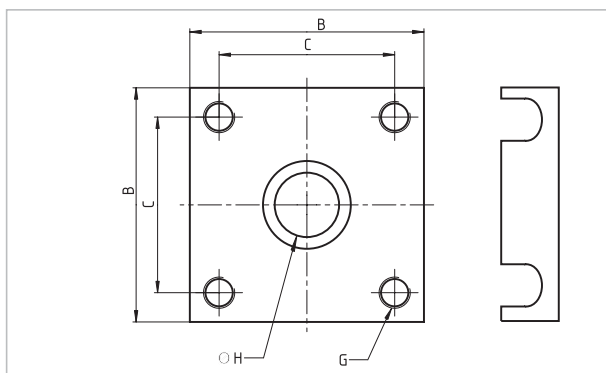

Bestellbeispiel | Order example

PR 4.454 [Kombirolle]
PR 4.454 [Combined Bearing]

AP 0 [Anschraubplatte]
AP 0 [Flange plate]

DS-0-0,5 [Distanzscheibe]
DS-0-0,5 [Washer type DS]

PR 0 Nb [Profil]
PR 0 Nb [Profile]

Typ Type	F _R KN F _R KN	F _A KN F _A KN	C KN C KN	C ₀ KN C ₀ KN	C _A KN C _A KN	C _{0A} KN C _{0A} KN	u/min max. r/pm max.	Gewicht kg Weight kg	Anschraubplatten Flange plates	Profile Profiles
PR 4.454	9,40	3,10	31,0	35,5	11	11	900	0,55	AP0 AP0-Q	PR 0 Nb
PR 4.455	11,30	3,73	45,5	51,0	11	11	800	0,80	AP1 AP1-Q	PR 1 Nb
PR 4.456	11,72	3,87	48,0	56,8	18	18	700	1,05	AP2 AP2-Q	PR 2 Nb
PR 4.458	20,47	6,76	68,0	72,0	23	23	600	1,65	AP3.1 AP3	PR 3 Nb
PR 4.461	21,68	7,16	81,0	95,0	25	27	500	2,85	AP4 AP4-Q	PR 4 Nb
PR 4.462	30,92	10,20	110,0	132,0	31	36	500	4,00	AP4 AP4-Q	PR 5 Nb
PR 4.463	54,02	17,80	151,0	192,0	31	36	400	6,70	AP6 AP6-Q	PR 6 Nb

C = Dynamic load capacity radial bearing (ISO 281/1), C₀ = Static load capacity radial bearing (ISO 76),
C_A = Dynamic load capacity axial bearing (ISO 281/1), C_{0A} = Static load capacity axial bearing (ISO 76),
F_R = Load capacity radial bearing max. allowable force between bearing and profile,
F_A = Load capacity axial bearing max. allowable force between bearing and profile



Axialrolle über Scheiben justierbar



Axial Bearing adjustable by shimes

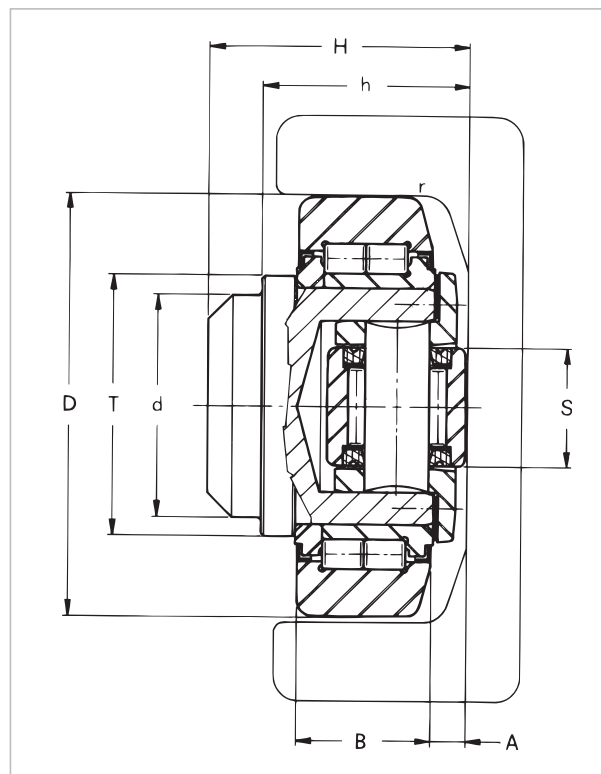

Justierung der Axialrolle

Die Einstellung des Maßes (A) erfolgt durch Distanzscheiben zwischen Hauptkörper und Bolzen der Seitenführungsrolle.

Scheiben der Stärke 0,5 und 1,0 mm sind auf Wunsch verfügbar.

Sonderbolzen auf Anfrage.

CAD Download in 2D/3D unter www.winkel.de

Adjusting of the Axial Bearing

The adjustment of dimension (A) is obtained by means of an insert positioned between the main body of the bearing and the housing of the side guide roller.

Washers with 0.5 + 1.0 mm thickness are available if required.

Special bolts on request.

CAD download in 2D/3D at www.winkel.de

Bestellbeispiel | Order example

4.072 [Kombirolle] AP 0 [Anschraubplatte] S-4.072-0,5 [Distanzscheibe für Kombirolle] DS-0-0,5 [Distanzscheibe für AP] 0 Nb [Profil]
 4.072 [Combined Bearing] AP 0 [Flange plate] S-4.072-0,5 [Washer for Combined Bearing] DS-0-0,5 [Washer type DS for AP] 0 Nb [Profile]

Type	D mm.	T mm.	d -0.05 mm.	H* mm.	h* mm.	B mm.	A mm.	S mm.	r mm.
Type	D mm.	T mm.	d -0.05 mm.	H* mm.	h* mm.	B mm.	A mm.	S mm.	r mm.
4.072	62,5	42	30	43,0	33,0	20	5,5	16	3
4.073	70,1	48	35	48,0	40,0	23	6,5	16	4
4.074	78,1	54	40	50,5	39,5	23	7,0	21	4
4.075	77,7	54	40	45,0	34,0	23	7,0	21	4
4.076	88,4	59	45	61,0	48,0	30	7,0	21	3
4.077	101,2	67	50	50,5	37,5	28	7,0	21	3
4.078	107,7	71	55	58,5	44,5	31	8,0	33	5
4.0784	107,7	71	60	69,0	55,0	31	8,0	33	5
4.079	123,0	80	60	75,5	59,5	37	8,0	33	5
4.080	149,0	103	60	89,0	69,0	45	15,0	50	5

C = Dyn. Tragzahl Radiallager (ISO 281/1), C₀ = Stat. Tragzahl Radiallager (ISO 76),

C_A = Dyn. Tragzahl Axiallager (ISO 281/1), C_{0A} = Stat. Tragzahl Axiallager (ISO 76),

F_r = Tragzahl Radiallager zulässige Belastung zwischen Rolle und Profil,

F_A = Tragzahl Axiallager zulässige Belastung zwischen Rolle und Profil

* Maße H und h ohne Distanzscheiben; max. +2 mm

Kombirollen | Combined Bearings



Passende Anschraubplatten

Fitting flange plates

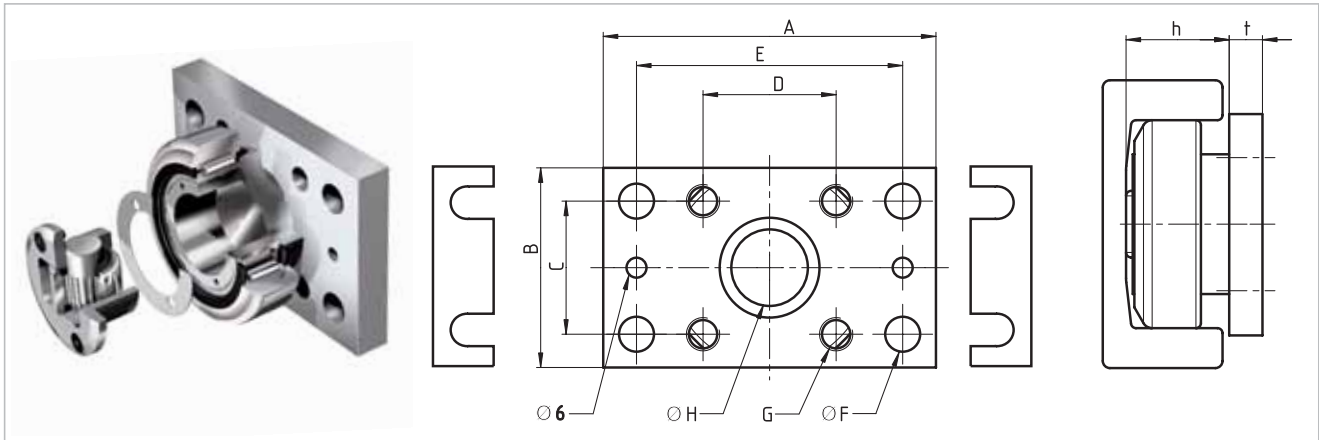

Typ Type	A	B	C	D	E	Ø F Ø F	G	Ø H Ø H	t	Distanzscheibe t=0,5mm Washer t=0.5mm	Distanzscheibe t=1,0mm Washer t=1.0mm
AP 0	100	60	40	40	80	10,5	M10	30	10	DS-0-0,5	DS-0-1,0
AP 1	120	80	50	50	90	12,5	M12	35	15	DS-1-0,5	DS-1-1,0
AP 2	120	80	50	50	90	12,5	M12	40	15	DS-2-0,5	DS-2-1,0
AP 3.1	160	100	60	60	120	17,0	M16	45	20	DS-3.1-0,5	DS-3.1-1,0
AP 4	180	120	80	80	140	17,0	M16	60	20	DS-4-0,5	DS-4-1,0
AP 6	200	150	100	100	160	17,0	M16	60	20	DS-6-0,5	DS-6-1,0

Anschraubplatten quadratisch Reihe AP-Q S. 74
Flange plates square series AP-Q page 74

Profile S. 52
Profiles page 52

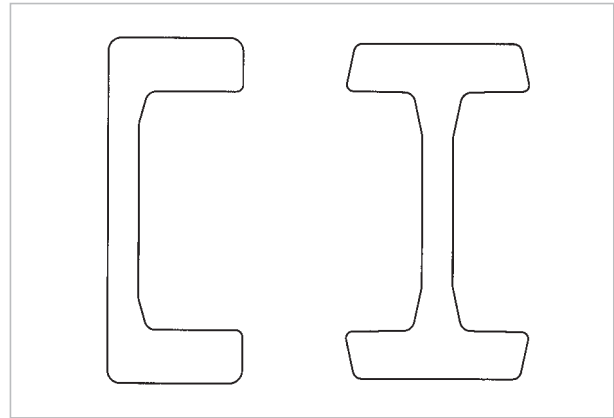
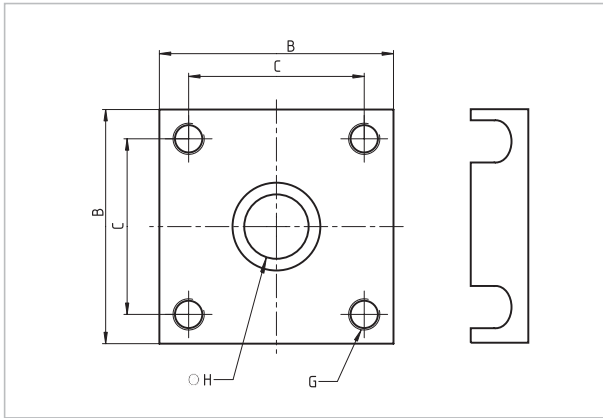

Typ Type	F _R KN F _R KN	F _A KN F _A KN	C KN C KN	C _o KN C _o KN	C _A KN C _A KN	C _{oA} KN C _{oA} KN	u/min max. r/pm max.	Gewicht kg Weight kg	Anschraubplatten Flange plates	Profile Standard Profiles standard
4.072	9,40	3,10	31,0	35,5	8	8	900	0,56	AP0 AP0-Q	0 Nb
4.073	11,30 (8,59)	3,73 (2,86)	45,5	51,0	14	14	800	0,85	AP1 AP1-Q	1 Nb (3018)
4.074	11,72	3,87	48,0	56,8	14	14	700	1,02	AP2 AP2-Q	2 Nb
4.075	(8,92)	(2,97)	48,0	56,8	14	14	700	0,92	-	(3019)
4.076	20,47 (15,57)	6,76 (5,19)	68,0	72,0	15	15	600	1,69	AP3.1 AP3	3 Nb (3020)
4.077	(15,47)	(5,15)	73,0	82,0	18	19	600	1,85	-	(2912)
4.078	(16,49)	(5,49)	81,0	95,0	31	36	500	2,38	-	(3100)
4.0784	21,68	7,16	81,0	95,0	31	36	500	2,80	AP4 AP4-Q	4 Nb
4.079	30,92 (23,52)	10,20 (7,84)	110,0	132,0	35	38	500	4,08	AP4 AP4-Q	5 Nb (3353)
4.080	37,81	17,80	151,0	192,0	68	71	400	6,70	AP6 AP6-Q	6 Nb

C = Dynamic load capacity radial bearing (ISO 281/1), C_o = Static load capacity radial bearing (ISO 76),
C_A = Dynamic load capacity axial bearing (ISO 281/1), C_{oA} = Static load capacity axial bearing (ISO 76),
F_R = Load capacity radial bearing max. allowable force between bearing and profile,
F_A = Load capacity axial bearing max. allowable force between bearing and profile
* Dimension H and h without washers; max. + 2 mm



Kombirollen | Combined Bearings

Präzisions-Kombirolle

Typ PR

Axialrolle über Scheiben justierbar



Precision Combined Bearing

Type PR

Axial Bearing adjustable by shims

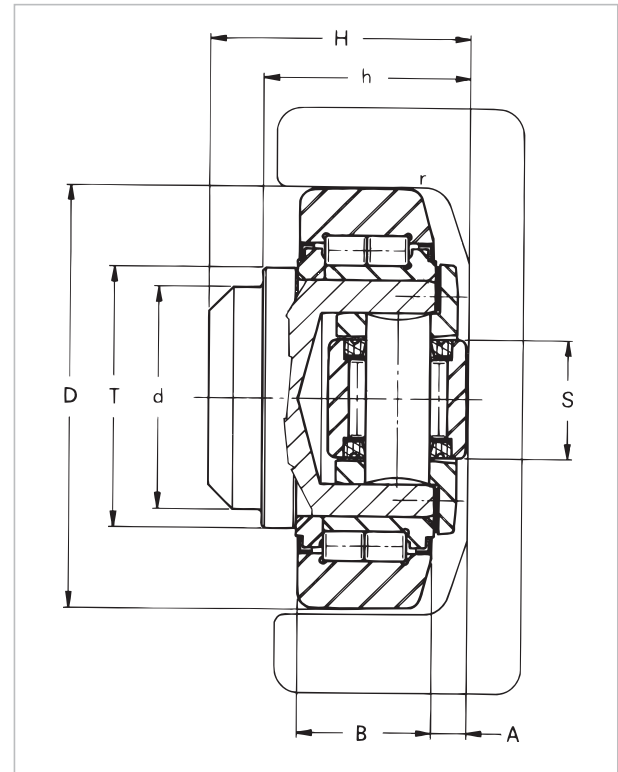

Justierung der Axialrolle

Die Einstellung des Maßes (A) erfolgt durch Distanzscheiben zwischen Hauptkörper und Bolzen der Seitenführungsrolle.
Scheiben der Stärke 0,5 und 1,0 mm sind auf Wunsch verfügbar.

Sonderbolzen auf Anfrage.

Adjusting of the Axial Bearing

The adjustment of dimension (A) is obtained by means of an insert positioned between the main body of the bearing and the housing of the side guide roller.
Washers with 0.5 + 1.0 mm thickness are available if required.

Special bolts on request.

Bestellbeispiel | Order example

PR 4.072 [Kombirolle] AP 0 [Anschraubplatte] S-PR 4.072-0,5 [Distanzscheibe für Kombirolle] DS-0-0,5 [Distanzscheibe für AP] PR 0 Nb [Profil]
PR 4.072 [Combined Bearing] AP 0 [Flange plate] S-PR 4.072-0,5 [Washer for Combined Bearing] DS-0-0,5 [Washer type DS for AP] PR 0 Nb [Profile]

Typ Type	D mm. D mm.	T mm. T mm.	d -0.05 mm. d -0.05 mm.	H* mm. H* mm.	h* mm. h* mm.	B mm. B mm.	A mm. A mm.	S mm. S mm.	r mm. r mm.
PR 4.072	64,8	42	30	43,0	33,0	20	5,5	16	3
PR 4.073	73,8	48	35	48,0	40,0	23	6,5	16	4
PR 4.074	81,8	54	40	50,5	39,5	23	7,0	21	4
PR 4.076	92,8	59	45	61,0	48,0	30	7,0	21	3
PR 4.0784	111,8	71	60	69,0	55,0	31	8,0	33	5
PR 4.079	127,8	80	60	75,5	59,5	37	8,0	33	5
PR 4.080	153,8	103	60	89,0	69,0	45	15,0	50	5

C = Dyn. Tragzahl Radiallager (ISO 281/1), C₀ = Stat. Tragzahl Radiallager (ISO 76),
C_A = Dyn. Tragzahl Axiallager (ISO 281/1), C_{0A} = Stat. Tragzahl Axiallager (ISO 76),
F_r = Tragzahl Radiallager zulässige Belastung zwischen Rolle und Profil,
F_A = Tragzahl Axiallager zulässige Belastung zwischen Rolle und Profil
* Maße H und h ohne Distanzscheiben; max. +2 mm



Passende Anschraubplatten

Fitting flange plates

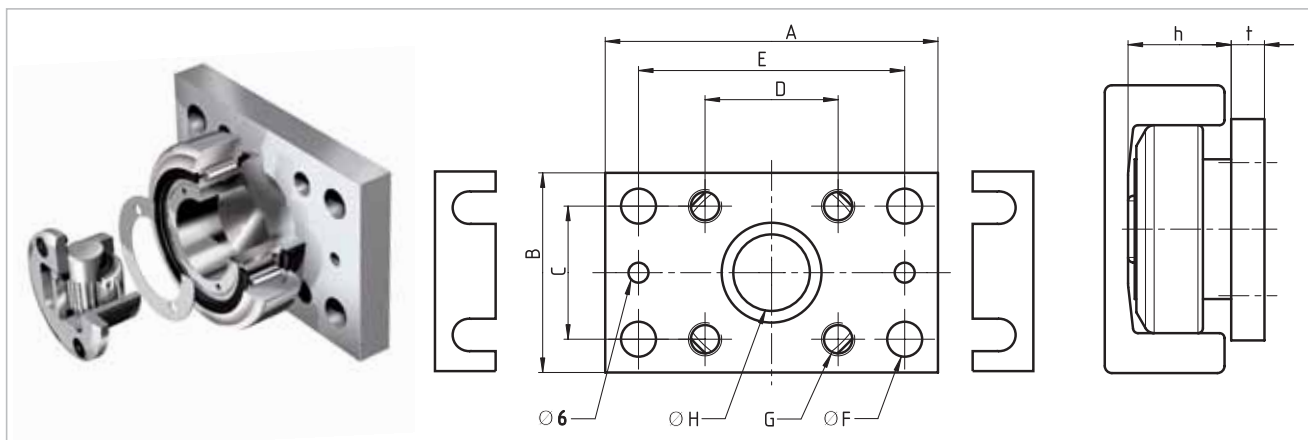

Typ Type	A	B	C	D	E	Ø F Ø F	G	Ø H Ø H	t t	Distanzscheibe t=0,5mm Washer t=0.5mm	Distanzscheibe t=1,0mm Washer t=1.0mm
AP 0	100	60	40	40	80	10,5	M10	30	10	DS-0-0,5	DS-0-1,0
AP 1	120	80	50	50	90	12,5	M12	35	15	DS-1-0,5	DS-1-1,0
AP 2	120	80	50	50	90	12,5	M12	40	15	DS-2-0,5	DS-2-1,0
AP 3.1	160	100	60	60	120	17,0	M16	45	20	DS-3.1-0,5	DS-3.1-1,0
AP 4	180	120	80	80	140	17,0	M16	60	20	DS-4-0,5	DS-4-1,0
AP 6	200	150	100	100	160	17,0	M16	60	20	DS-6-0,5	DS-6-1,0

Anschraubplatten quadratisch Reihe AP-Q S. 74
Flange plates square series AP-Q page 74

Profile S. 56
Profiles page 56

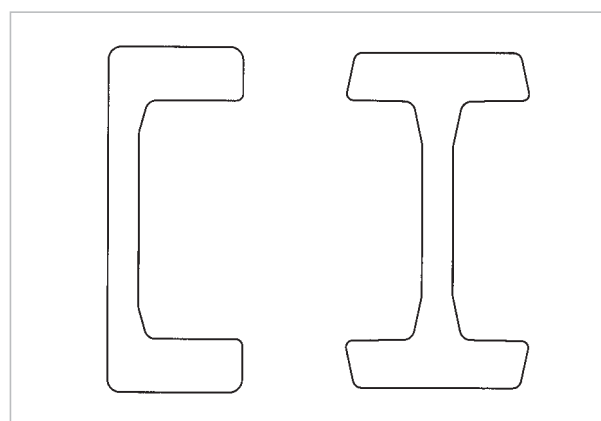
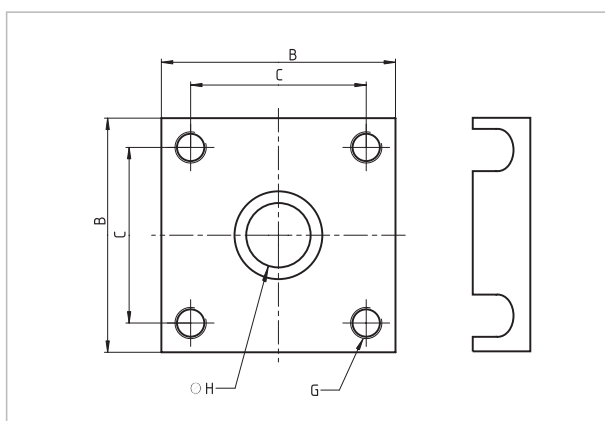

Typ Type	F _R KN F _R KN	F _A KN F _A KN	C KN C KN	C ₀ KN C ₀ KN	C _A KN C _A KN	C _{0A} KN C _{0A} KN	u/min max. r/pm max.	Gewicht kg Weight kg	Anschraubplatten Flange plates	Profile Standard Profiles standard
PR 4.072	9,40	3,10	31,0	35,5	8	8	900	0,56	AP0 AP0-Q	PR 0 Nb
PR 4.073	11,30	3,73	45,5	51,0	14	14	800	0,85	AP1 AP1-Q	PR 1 Nb
PR 4.074	11,72	3,87	48,0	56,8	14	14	700	1,02	AP2 AP2-Q	PR 2 Nb
PR 4.076	20,47	6,76	68,0	72,0	15	15	600	1,69	AP3.1 AP3	PR 3 Nb
PR 4.0784	21,68	7,16	81,0	95,0	31	36	500	2,80	AP4 AP4-Q	PR 4 Nb
PR 4.079	30,92	10,20	110,0	132,0	35	38	500	4,08	AP4 AP4-Q	PR 5 Nb
PR 4.080	37,81	17,80	151,0	192,0	68	71	400	6,70	AP6 AP6-Q	PR 6 Nb

C = Dynamic load capacity radial bearing (ISO 281/1), C₀ = Static load capacity radial bearing (ISO 76),
C_A = Dynamic load capacity axial bearing (ISO 281/1), C_{0A} = Static load capacity axial bearing (ISO 76),
F_R = Load capacity radial bearing max. allowable force between bearing and profile,
F_A = Load capacity axial bearing max. allowable force between bearing and profile
* Dimension H and h without washers; max. + 2 mm



Kombirolle justierbar mit Oilamid*-Einsatz



Die Einstellung des Maßes (A) erfolgt durch Distanzscheiben zwischen Hauptkörper und Oilamid-Einsatz. Scheiben der Stärke 0,5 und 1,0 mm sind auf Wunsch verfügbar.

Hinweis: Bei hoher axialer Belastung ist eine Bearbeitung der Gleitfläche zu empfehlen.

Sonderbolzen auf Anfrage.

CAD Download in 2D/3D unter www.winkel.de

*Oilamid ist ein hochabriebfester selbstschmierender Polyamid.

The adjustment of dimension (A) is obtained by means of an insert positioned between the main body of the bearing and the oilamid insert.

Washers with 0.5 + 1.0 mm thickness are available if required.

Notice: At high axial forces we recommend to mill the axial raceway of the profile.

Special bolts on request.

CAD download in 2D/3D at www.winkel.de

*Oilamid is a high resistant, self lubricant Polyamide

Combined Bearing adjustable with Oilamid* insert

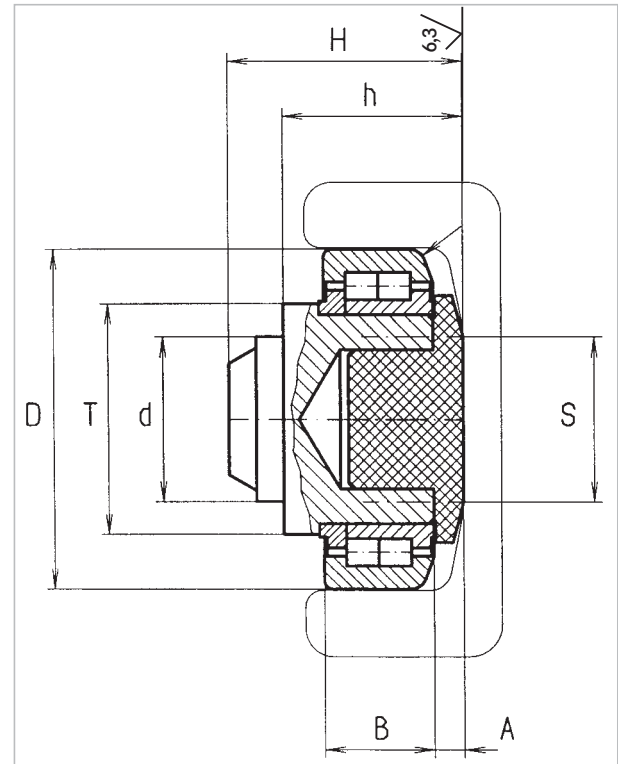

nur 4.052 P | only 4.052 P

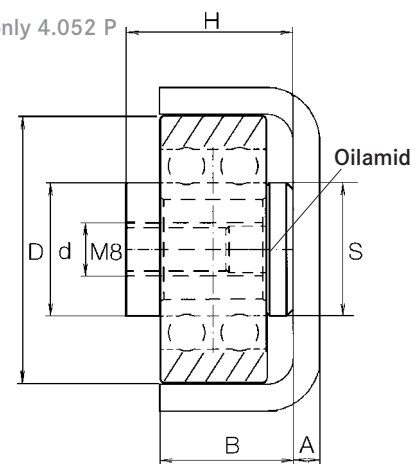

Typ Type	D mm. D mm.	T mm. T mm.	d -0.05 mm. d -0.05 mm.	H* mm. H* mm.	h* mm. h* mm.	B mm. B mm.	A mm. A mm.	S mm. S mm.	r mm. r mm.
4.052 P	40	-	20	25,0	-	16	4,0	ø 20	-
4.072 P	62,5	42	30	43,0	33,0	20	5,5	ø 25	3
4.073 P	70,1	48	35	48,0	40,0	23	6,5	ø 33	4
4.074 P	78,1	54	40	50,5	39,5	23	7,0	ø 40	4
4.076 P	88,4	59	45	61,0	48,0	30	7,0	ø 45	3
4.0784 P	107,7	71	60	69,0	55,0	31	8,0	ø 60	5
4.079 P	123,0	80	60	75,5	59,5	37	8,0	ø 70	5
4.080 P	149,0	103	60	82,0	62,0	45	8,0	ø 100	5
4.085 P	180	124	100	99,2	79,8	57,3	10,0	ø 112	5

C = Dyn. Tragzahl Radiallager (ISO 281/1), C₀ = Stat. Tragzahl Radiallager (ISO 76),

F_R = Tragzahl Radiallager zulässige Belastung zwischen Rolle und Profil,

F_A = Tragzahl Axiallager zulässige Belastung zwischen Rolle und Profil

* Maße H und h ohne Distanzscheiben; max. +2 mm



Passende Anschraubplatten

Fitting flange plates

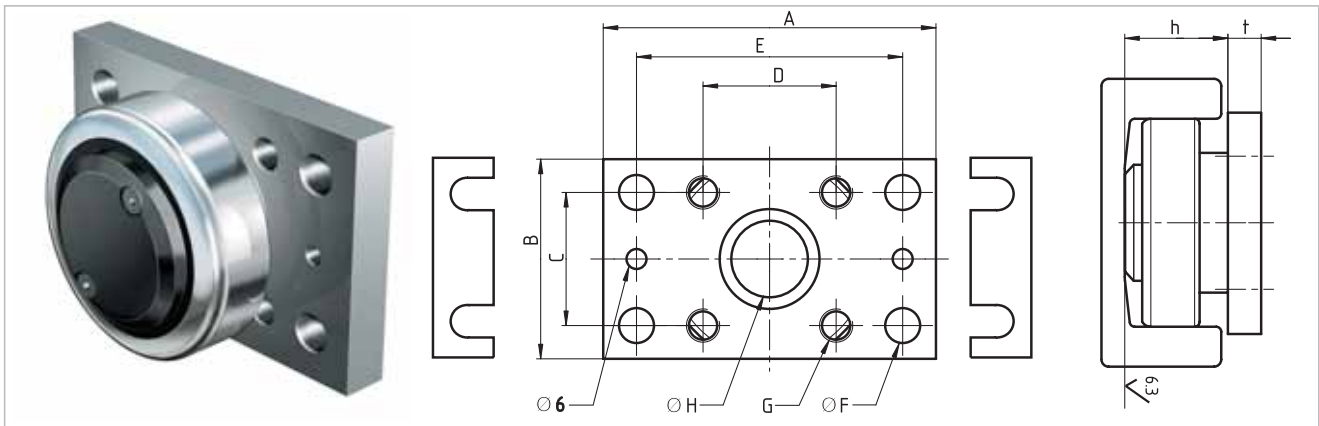

Typ Type	A	B	C	D	E	Ø F Ø F	G	Ø H Ø H	t	Distanzscheibe t=0,5mm Washer t=0.5mm	Distanzscheibe t=1,0mm Washer t=1.0mm
AP A	65	45	30	30	50	6,5	M 6	15	5	DS-A-0,5	DS-A-1,0
AP 0	100	60	40	40	80	10,5	M 10	30	10	DS-0-0,5	DS-0-1,0
AP 1	120	80	50	50	90	12,5	M 12	35	15	DS-1-0,5	DS-1-1,0
AP 2	120	80	50	50	90	12,5	M 12	40	15	DS-2-0,5	DS-2-1,0
AP 3.1	160	100	60	60	120	17,0	M 16	45	20	DS-3.1-0,5	DS-3.1-1,0
AP 4	180	120	80	80	140	17,0	M 16	60	20	DS-4-0,5	DS-4-1,0
AP 6	200	150	100	100	160	17,0	M 16	60	20	DS-6-0,5	DS-6-1,0

Anschraubplatten quadratisch Reihe AP-Q S. 74
Flange plates square series AP-Q page 74

Profile S. 52
Profiles page 52

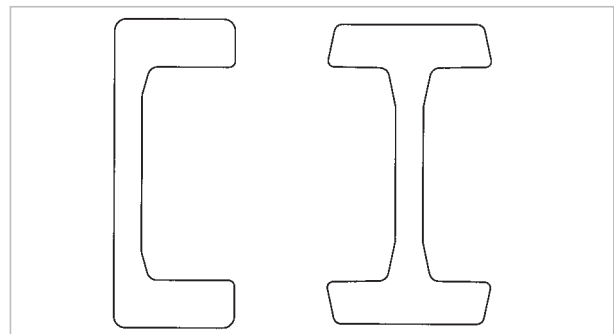
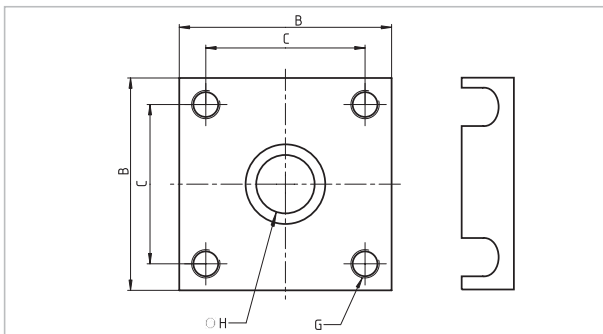

Bestellbeispiel | Order example

4.072 [Kombirolle] AP 0 [Anschraubplatte] S-4.072-0,5 [Distanzscheibe für Kombirolle] DS-0-0,5 [Distanzscheibe für AP] 0 Nb [Profil]
4.072 [Combined Bearing] AP 0 [Flange plate] S-4.072-0,5 [Washer for Combined Bearing] DS-0-0,5 [Washer type DS for AP] 0 Nb [Profile]

Typ Type	F _R KN F _R KN	F _A KN F _A KN	C KN C KN	C ₀ KN C ₀ KN	u/min max. r/pm max.	Gewicht kg Weight kg	Anschraubplatten Flange plates	Profile Profiles
4.052 P	0,8	3,1	0,8	0,85	800	0,15	APA APA-Q	A
4.072 P	9,4	4,0	31,0	35,5	900	0,49	AP0 AP0-Q	0 Nb
4.073 P	11,3	6,7	45,5	51,0	800	0,74	AP1 AP1-Q	1 Nb
4.074 P	11,72	7,2	48,0	56,8	700	0,94	AP2 AP2-Q	2 Nb
4.076 P	20,47	8,9	68,0	72,0	600	1,57	AP3.1 AP3	3 Nb
4.0784 P	21,68	14,4	81,0	95,0	500	2,63	AP4 AP4-Q	4 Nb
4.079 P	30,92	38,4	110,0	132,0	500	3,90	AP4 AP4-Q	5 Nb
4.080 P	37,81	41,6	151,0	192,0	400	6,50	AP6 AP6-Q	6 Nb
4.085 P	64,7	41,6	207	243	200	11,50	AP90Q	8 Nb

C = Dynamic load capacity radial bearing (ISO 281/1), C₀ = Static load capacity radial bearing (ISO 76),

F_R = Load capacity radial bearing max. allowable force between bearing and profile,

F_A = Load capacity axial bearing max. allowable force between bearing and profile

* Dimension H and h without washers; max. 2 mm



Kombirollen | Combined Bearings

Präzisions-Kombirolle
 Typ PR-P
 Kombirolle justierbar mit
 Oilamid*-Einsatz

Precision Combined Bearing
 Type PR-P
 Combined Bearing adjustable with
 Oilamid* insert

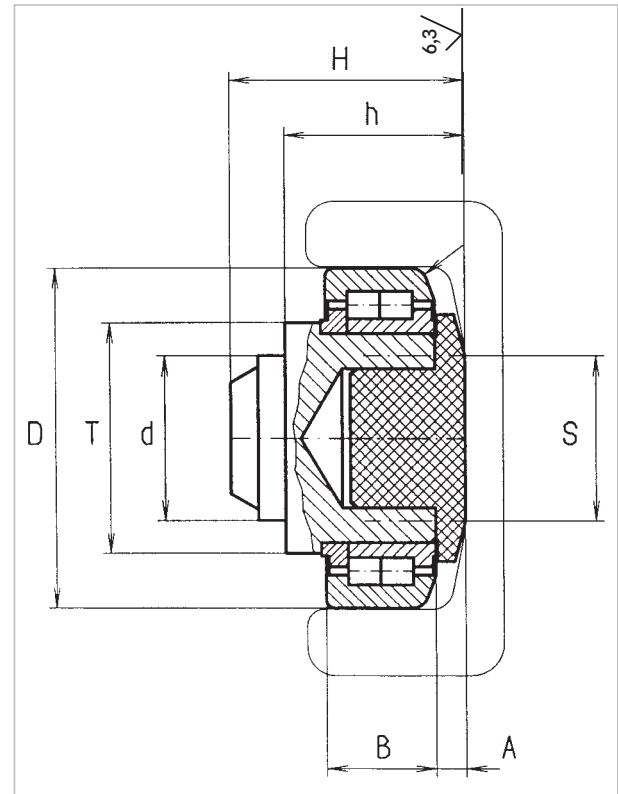

Die Einstellung des Maßes (A) erfolgt durch Distanzscheiben zwischen Hauptkörper und Oilamid-Einsatz.
 Scheiben der Stärke 0,5 und 1,0 mm sind auf Wunsch verfügbar.

Hinweis: Bei hoher axialer Belastung ist eine Bearbeitung der Gleitfläche zu empfehlen.

Sonderbolzen auf Anfrage.

*Oilamid ist ein hochabriebfester selbstschmierender Polyamid.

The adjustment of dimension (A) is obtained by means of an insert positioned between the main body of the bearing and the oilamide insert.

Washers with 0.5 + 1.0 mm thickness are available if required.

Notice: At high axial forces we recommend to mill the axial raceway of the profile.

Special bolts on request.

*Oilamid is a high resistant, self lubricant Polyamide

Bestellbeispiel | Order example

PR 4.072 P [Kombirolle] AP 0 [Anschraubplatte] S-PR 4.072-0,5 [Distanzscheibe für Kombirolle] DS-0-0,5 [Distanzscheibe für AP] PR 0 Nb [Profil]
 PR 4.072 P [Combined Bearing] AP 0 [Flange plate] S-PR 4.072-0,5 [Washer for Combined Bearing] DS-0-0,5 [Washer type DS for AP] PR 0 Nb [Profile]

Typ Type	D mm. D mm.	T mm. T mm.	d -0.05 mm. d -0.05 mm.	H* mm. H* mm.	h* mm. h* mm.	B mm. B mm.	A mm. A mm.	S mm. S mm.	r mm. r mm.
PR 4.072 P	64,8	42	30	43,0	33,0	20	5,5	∅ 25	3
PR 4.073 P	73,8	48	35	48,0	40,0	23	6,5	∅ 33	4
PR 4.074 P	81,8	54	40	50,5	39,5	23	7,0	∅ 40	4
PR 4.076 P	92,8	59	45	61,0	48,0	30	7,0	∅ 45	3
PR 4.0784 P	111,8	71	60	69,0	55,0	31	8,0	∅ 60	5
PR 4.079 P	127,8	80	60	75,5	59,5	37	8,0	∅ 70	5
PR 4.080 P	153,8	103	60	82,0	62,0	45	8,0	∅ 100	5

C = Dyn. Tragzahl Radiallager (ISO 281/1), C₀ = Stat. Tragzahl Radiallager (ISO 76),

F_R = Tragzahl Radiallager zulässige Belastung zwischen Rolle und Profil,

F_A = Tragzahl Axiallager zulässige Belastung zwischen Rolle und Profil

* Maße H und h ohne Distanzscheiben; max. +2 mm



Passende Anschraubplatten

Fitting flange plates

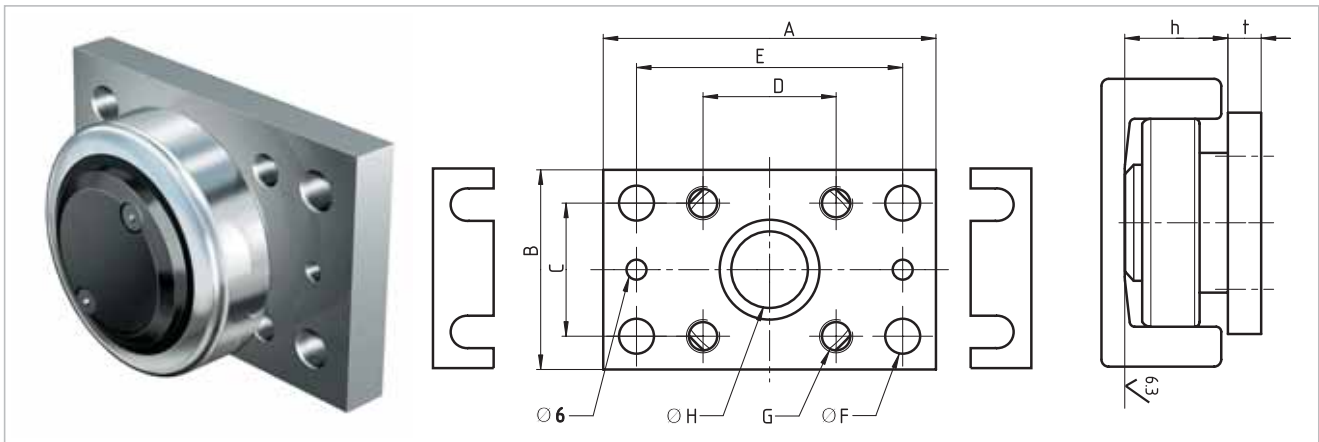

Typ Type	A	B	C	D	E	Ø F Ø F	G	Ø H Ø H	t	Distanzscheibe t=0,5mm Washer t=0.5mm	Distanzscheibe t=1,0mm Washer t=1.0mm
AP 0	100	60	40	40	80	10,5	M10	30	10	DS-0-0,5	DS-0-1,0
AP 1	120	80	50	50	90	12,5	M12	35	15	DS-1-0,5	DS-1-1,0
AP 2	120	80	50	50	90	12,5	M12	40	15	DS-2-0,5	DS-2-1,0
AP 3.1	160	100	60	60	120	17,0	M16	45	20	DS-3.1-0,5	DS-3.1-1,0
AP 4	180	120	80	80	140	17,0	M16	60	20	DS-4-0,5	DS-4-1,0
AP 6	200	150	100	100	160	17,0	M16	60	20	DS-6-0,5	DS-6-1,0

Anschraubplatten quadratisch Reihe AP-Q S. 74
Flange plates square series AP-Q page 74

Profile S. 56
Profiles page 56

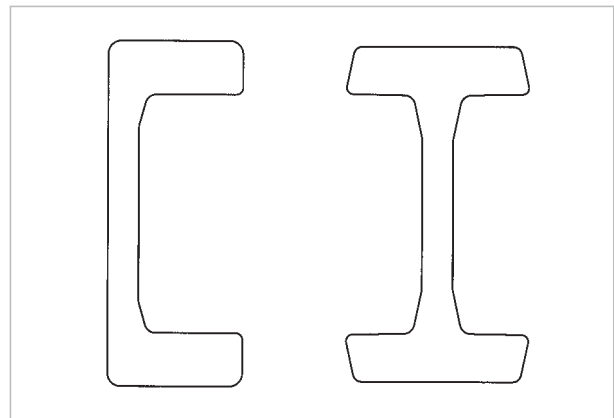
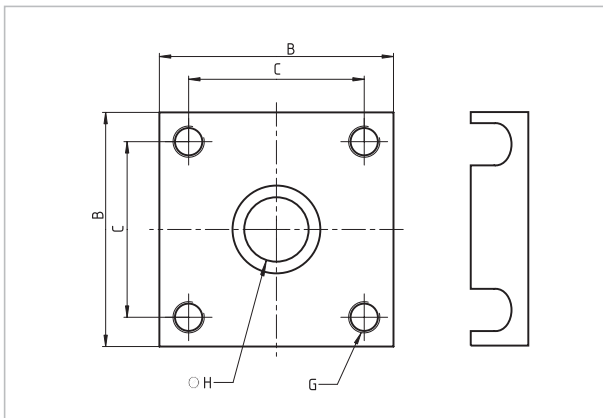

Typ Type	F _R KN F _R KN	F _A KN F _A KN	C KN C KN	C ₀ KN C ₀ KN	u/min max. r/pm max.	Gewicht kg Weight kg	Anschraubplatten Flange plates	Profile Profiles
PR 4.072 P	9,40	4,0	31,0	35,5	900	0,49	AP0 AP0-Q	PR 0 Nb
PR 4.073 P	11,30	6,7	45,5	51,0	800	0,74	AP1 AP1-Q	PR 1 Nb
PR 4.074 P	11,72	7,2	48,0	56,8	700	0,94	AP2 AP2-Q	PR 2 Nb
PR 4.076 P	20,47	8,9	68,0	72,0	600	1,57	AP3.1 AP3	PR 3 Nb
PR 4.0784 P	21,68	14,4	81,0	95,0	500	2,63	AP4 AP4-Q	PR 4 Nb
PR 4.079 P	30,92	38,4	110,0	132,0	500	3,90	AP4 AP4-Q	PR 5 Nb
PR 4.080 P	37,81	41,6	151,0	192,0	400	6,50	AP6 AP6-Q	PR 6 Nb

C = Dynamic load capacity radial bearing (ISO 281/1), C₀ = Static load capacity radial bearing (ISO 76),
F_R = Load capacity radial bearing max. allowable force between bearing and profile,
F_A = Load capacity axial bearing max. allowable force between bearing and profile
* Dimension H and h without washers; max. 2 mm



Kombirollen | Combined Bearings

Jumbo Kombirolle
Axialrolle justierbar



Jumbo Combined Bearing
Axial Bearing adjustable

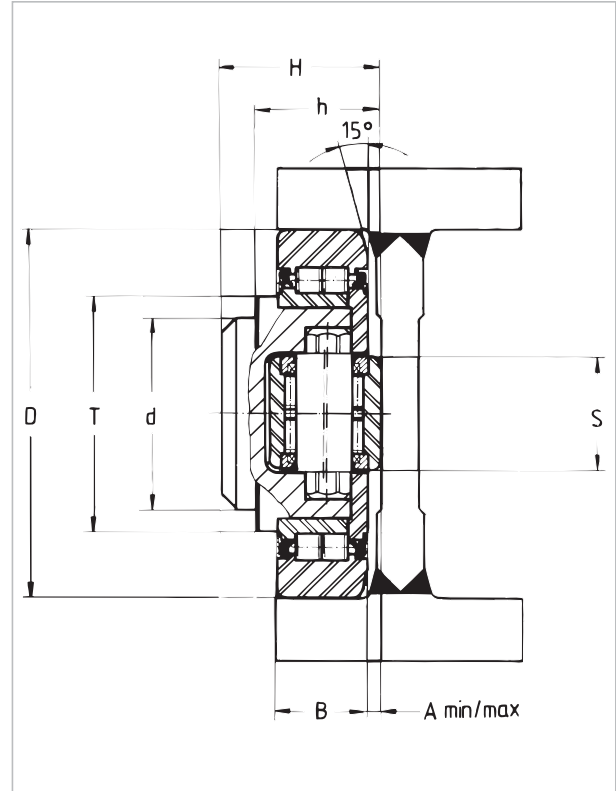

Die Einstellung des Maßes (A) erfolgt durch verdrehen des Bolzens der Seitenführungsrolle.
Der Bolzen ist exzentrisch und hat 5 Stellpositionen.
Das Radiallager ist nachschmierbar.

Andere Lagergrößen auf Anfrage.

CAD Download in 2D/3D unter www.winkel.de

The adjustment of dimension (A) is obtained by turning the bolt of the side guide roller.
The bolt is eccentric and has 5 adjustment positions.
The radial bearing can be relubricated.

Other bearing types on request.

CAD download in 2D/3D at www.winkel.de

Bestellbeispiel | Order example

4.089 [Kombirolle]
4.089 [Combined Bearing]

AP 89-Q [Anschraubplatte]
AP 89-Q [Flange plate]

DS 89-0,5 [Distanzscheibe]
DS 89-0,5 [Washer type DS]

St 10 [Profil]
St 10 [Profile]

NEU
NEW

Typ Type	D mm. D mm.	T mm. T mm.	d -0.05 mm. d -0.05 mm.	H mm. H mm.	h mm. h mm.	B mm. B mm.	A mm. A mm.	S mm. S mm.
4.085	180	124	100	95,7 - 98,7	76,3 - 79,3	57,3	6,5 - 9,5	60
4.089	165	113	80	69,0 - 72,0	53,0 - 56,0	40	5,0 - 8,0	50
4.090	190	124	100	84,5 - 87,5	64,5 - 67,5	48	6,5 - 9,5	60
4.091	220	146	110	94,5 - 97,5	74,5 - 77,5	58	6,5 - 9,5	75
4.092	250	168	120	102,0 - 105,0	77,0 - 80,0	60	7,0 - 10,0	75
4.093	280	188	150	119,5 - 123,5	89,5 - 93,5	72	7,5 - 11,5	90

C = Dyn. Tragzahl Radiallager (ISO 281/1), C₀ = Stat. Tragzahl Radiallager (ISO 76),
C_A = Dyn. Tragzahl Axiallager (ISO 281/1), C_{0A} = Stat. Tragzahl Axiallager (ISO 76),
F_R = Tragzahl Radiallager zulässige Belastung zwischen Rolle und Profil,
F_A = Tragzahl Axiallager zulässige Belastung zwischen Rolle und Profil



Passende Anschraubplatten

Fitting flange plates

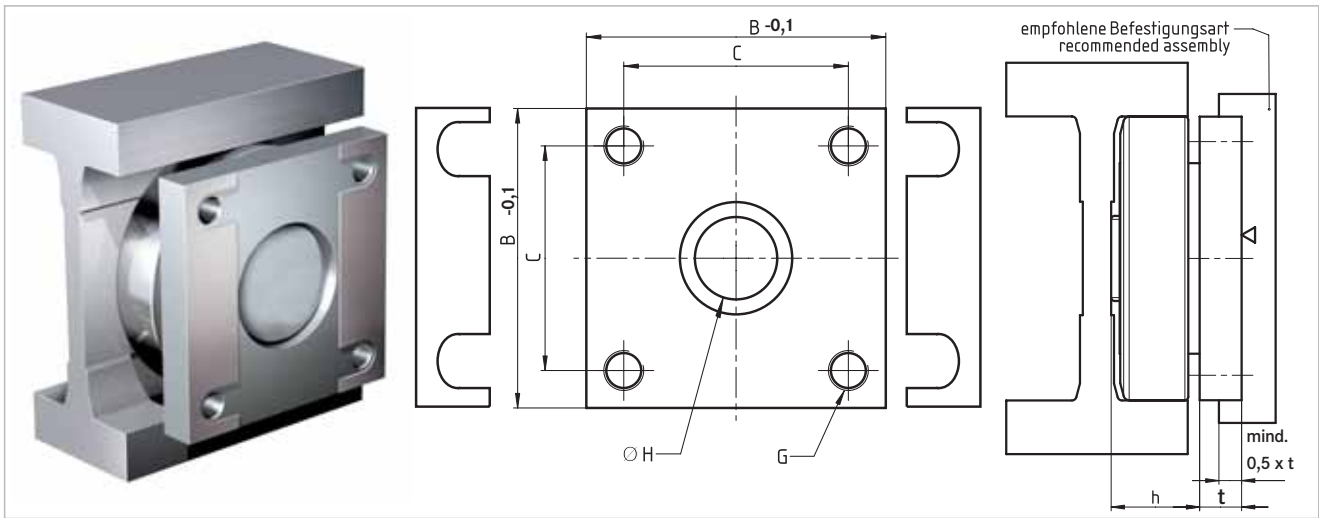

Typ Type	B-0,1 B-0,1	C C	G G	Ø H Ø H	h h	t t	Distanzscheibe t=0,5mm Washer t=0.5mm	Distanzscheibe t=1,0mm Washer t=1.0mm
AP 89-Q	165	125	M20	80	53,0 - 56,0	23	DS-89-0,5	DS-89-1,0
AP 90-Q (4.085 + AP 90-Q)	190	150	M20	100	64,5 - 67,5 (76,0-79,3)	28	DS-90-0,5	DS-90-1,0
AP 91-Q	220	176	M24	110	74,5 - 77,5	33	DS-91-0,5	DS-91-1,0
AP 92-Q	250	206	M24	120	77,0 - 80,0	37	DS-92-0,5	DS-92-1,0
AP 93-Q	280	220	M30	150	89,5 - 93,5	37	DS-93-0,5	DS-93-1,0

NEU
NEW Profile S. 54
Profiles page 54

Profile S. 64
Profiles page 64

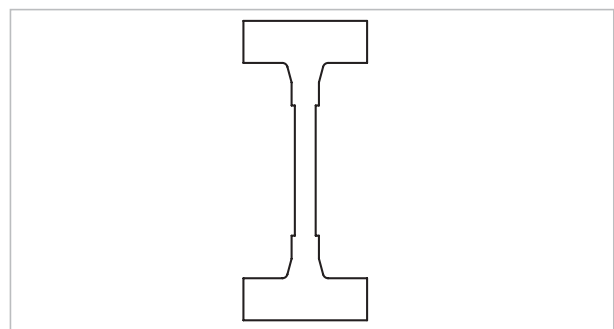
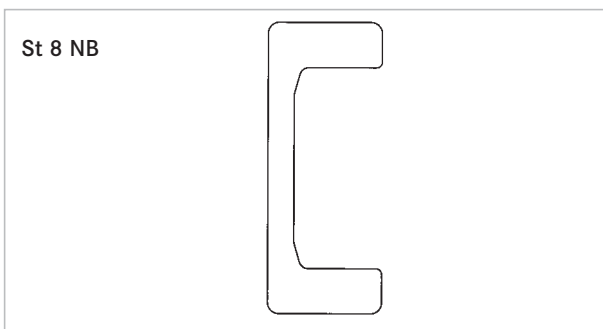

Typ Type	F _R KN F _R KN	F _A KN F _A KN	C KN C KN	C _o KN C _o KN	C _A KN C _A KN	C _{oA} KN C _{oA} KN	u/min max. r/pm max.	Gewicht kg Weight kg	Anschraubplatten Flange plates	Profile Profiles
4.085	64,7	19,4	207	243	73	83	200	11,5	AP 90-Q	Standard 8 NB
4.089	41,71	13,91	190	230	68	71	120	9,2	AP 89-Q	Standard 10
4.090	58,00	19,40	207	243	73	83	100	10,6	AP 90-Q	Standard 16
4.091	84,00	28,00	313	387	105	136	90	17,3	AP 91-Q	Standard 18
4.092	101,50	33,90	327	434	105	136	75	23,9	AP 92-Q	Standard 28
4.093	139,40	46,50	421	625	144	210	50	36,0	AP 93-Q	Stand. 36 + 42

C = Dynamic load capacity radial bearing (ISO 281/1), C_o = Static load capacity radial bearing (ISO 76),
 C_A = Dynamic load capacity axial bearing (ISO 281/1), C_{oA} = Static load capacity axial bearing (ISO 76),
 F_R = Load capacity radial bearing max. allowable force between bearing and profile,
 F_A = Load capacity axial bearing max. allowable force between bearing and profile



Radiallager



Radial Bearing

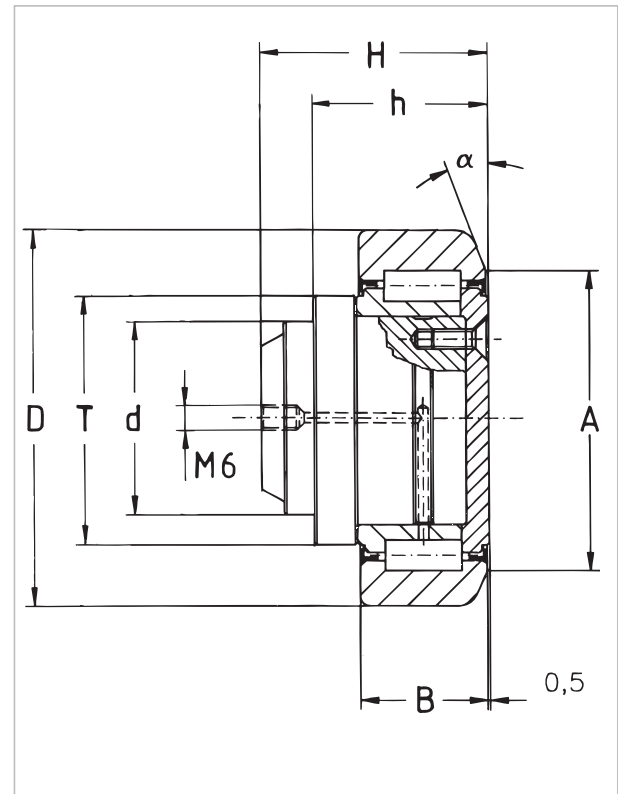

Technische Daten:

- die Außenringe sind aus Einsatzstahl
UNI 16 CrNi 4 gehärtet 62+2 HRC
- die Innenringe sind aus Stahl
DIN 100 Cr 6 gehärtet 62-2 HRC
- flachköpfige Rollen aus Stahl
DIN 100 Cr 6 gehärtet 59 ÷ 64 HRC
- Anschweißbolzen aus Stahl S355 J2G3 (St 52.3)
- Bolzertoleranz -0,05 mm
- Nachschmierbarkeit für Rollen 2.054 ÷ 2.063
- Radiallager werden bei der Montage mit Schmierfett
Grad 3 (z.B. Shell Alvania 3, Esso Beacon 3) befüllt

Technical characteristics:

- outer rings are made from case-hardened steel
UNI 16 CrNi 4 hardened at 62+2HRC
- inner rings are made from bearing steel
En 31-SAE 52100 hardened at 62-2 HRC
- cylindrical rollers have flat ground heads, made from
En 31-SAE 52100 steel hardened at 59 ÷ 64 HRC
- welding bolts are made from UNI FE 510.C
- bolt tolerance -0.05 mm
- bearings from 2.054 to 2.063 are relubricateable
- bearings are lubricated with grease grade 3
(e.g. Shell Alvania 3, Esso Beacon 3)

CAD Download in 2D/3D unter www.winkel.de

CAD download in 2D/3D at www.winkel.de

Typ Type	D mm. D mm.	T mm. T mm.	d -0.05 mm. d -0.05 mm.	H mm. H mm.	h mm. h mm.	B mm. B mm.	A mm. A mm.	α mm. α mm.
2.054	62,5	42	30	36,5	29,5	20	50	20°
2.055	70,1	48	35	42,0	34,0	23	57	20°
2.056	77,7	53	40	45,5	34,0	23	61	20°
2.058	88,4	59	45	54,0	41,0	30	68	20°
2.061	107,7	71	60	65,5	51,5	31	82	20°
2.062	123,0	80	60	67,8	51,5	37	92	20°
2.063	149,0	103	60	74,0	54,0	45	116	15°

C = Dyn. Tragzahl Radiallager (ISO 281/1), C₀ = Stat. Tragzahl Radiallager (ISO 76),
F_r = Tragzahl Radiallager zulässige Belastung zwischen Rolle und Profil



Passende Anschraubplatten

Fitting flange plates

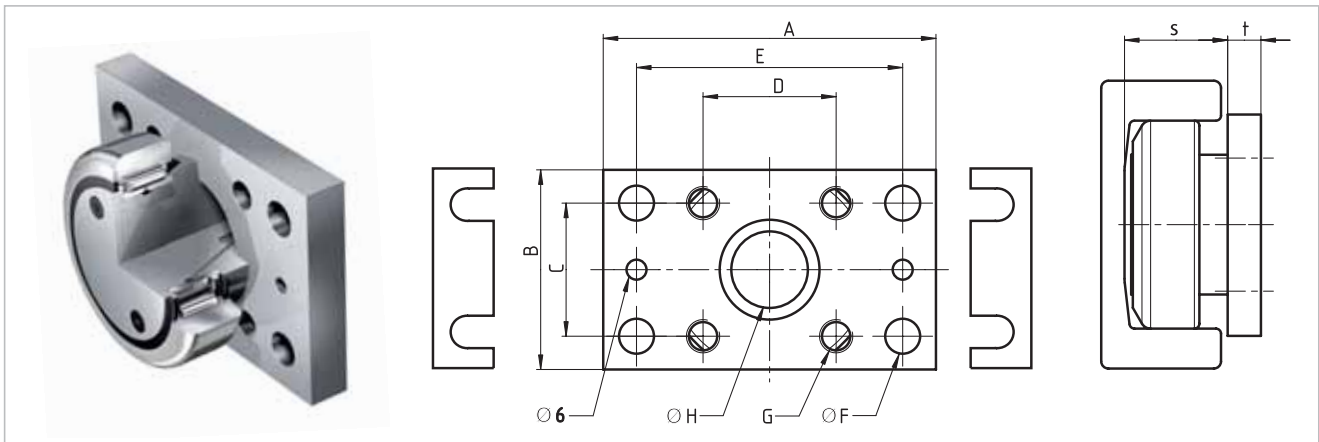

Typ Type	A	B	C	D	E	Ø F Ø F	G	Ø H Ø H	s	t	Distanzscheibe t=0,5mm Washer t=0.5mm	Distanzscheibe t=1,0mm Washer t=1.0mm
AP 0	100	60	40	40	80	10,5	M10	30	30,5	10	DS-0-0,5	DS-0-1,0
AP 1	120	80	50	50	90	12,5	M12	35	36,0	15	DS-1-0,5	DS-1-1,0
AP 2	120	80	50	50	90	12,5	M12	40	36,5	15	DS-2-0,5	DS-2-1,0
AP 3.1	160	100	60	60	120	17,0	M16	45	44,0	20	DS-3.1-0,5	DS-3.1-1,0
AP 4	180	120	80	80	140	17,0	M16	60	56,0	20	DS-4-0,5	DS-4-1,0
AP 6	200	150	100	100	160	17,0	M16	60	58,5	20	DS-6-0,5	DS-6-1,0

Anschraubplatten quadratisch Reihe AP-Q S. 74
Flange plates square series AP-Q page 74

Profile S. 52
Profiles page 52

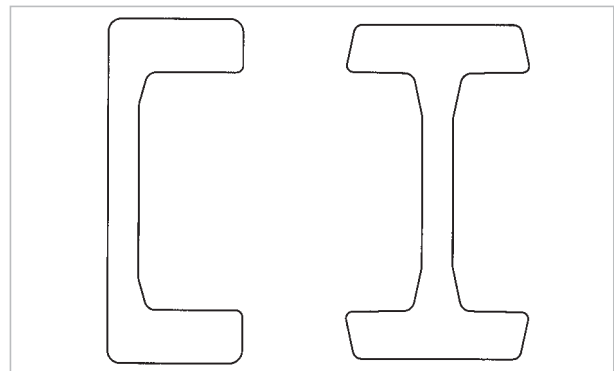
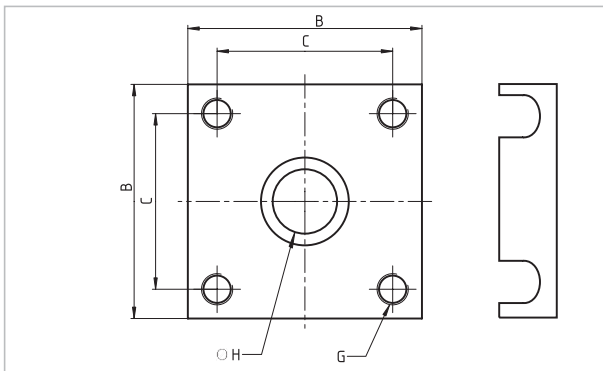

Bestellbeispiel | Order example

2.054 [Radiallager]
2.054 [Radial Bearing]

AP 0 [Anschraubplatte]
AP 0 [Flange plate]

DS-0-0,5 [Distanzscheibe]
DS-0-0,5 [Washer type DS]

0 Nb [Profil]
0 Nb [Profile]

Typ Type	F _R KN F _R KN	C KN C KN	C ₀ KN C ₀ KN	u/min max. r/pm max.	Gewicht kg Weight kg	Anschraubplatten Flange plates	Profile Profiles
2.054	9,40	31,0	35,5	900	0,55	AP0 AP0-Q	0 Nb
2.055	11,30	45,5	51,0	900	0,80	AP1 AP1-Q	1 Nb
2.056	11,72	48,0	56,8	800	1,05	AP2 AP2-Q	2 Nb
2.058	20,47	68,0	72,0	750	1,70	AP3.1 AP3	3 Nb
2.061	21,68	81,0	95,0	650	2,90	AP4 AP4-Q	4 Nb
2.062	30,92	110,0	132,0	550	4,00	AP4 AP4-Q	5 Nb
2.063	54,02	151,0	192,0	450	6,70	AP6 AP6-Q	6 Nb

C = Dynamic load capacity radial bearing (ISO 281/1), C₀ = Static load capacity radial bearing (ISO 76),
F_R = Load capacity radial bearing max. allowable force between bearing and profile,



Präzisions-Radiallager Typ PR



Precision Radial Bearing Type PR

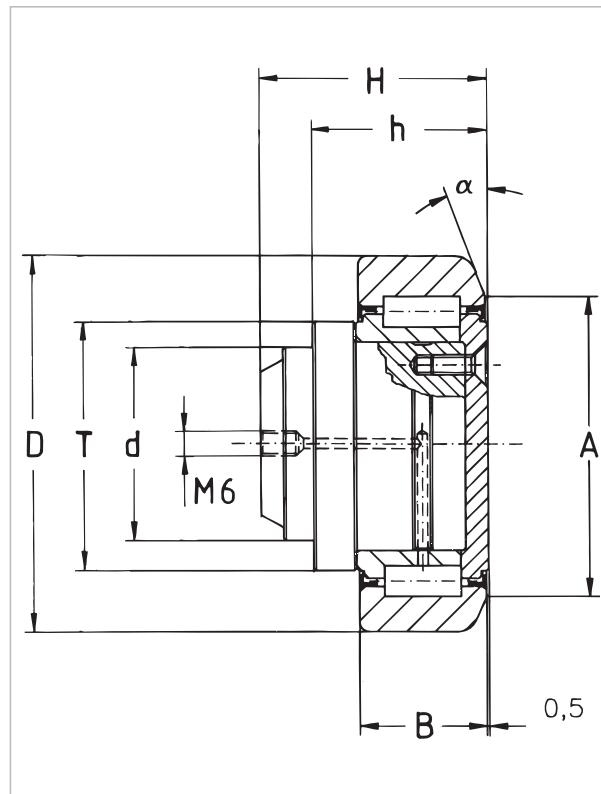

Technische Daten:

- die Außenringe sind aus Einsatzstahl
UNI 16 CrNi 4 gehärtet 62+2 HRC
- die Innenringe sind aus Stahl
DIN 100 Cr 6 gehärtet 62-2 HRC
- flachköpfige Rollen aus Stahl
DIN 100 Cr 6 gehärtet 59 ÷ 64 HRC
- Anschweißbolzen aus Stahl S355 J2G3 (St 52.3)
- Bolzentoleranz -0,05 mm
- Nachschmierbarkeit für Rollen 2.054 ÷ 2.063
- Radiallager werden bei der Montage mit Schmierfett
Grad 3 (z.B. Shell Alvania 3, Esso Beacon 3) befüllt

Technical characteristics:

- outer rings are made from case-hardened steel
UNI 16 CrNi 4 hardened at 62+2HRC
- inner rings are made from bearing steel
En 31-SAE 52100 hardened at 62-2 HRC
- cylindrical rollers have flat ground heads, made from
En 31-SAE 52100 steel hardened at 59 ÷ 64 HRC
- welding bolts are made from UNI FE 510.C
- bolt tolerance -0.05 mm
- bearings from 2.054 to 2.063 are relubricateable
- bearings are lubricated with grease grade 3
(e.g. Shell Alvania 3, Esso Beacon 3)

Typ Type	D mm. D mm.	T mm. T mm.	d -0.05 mm. d -0.05 mm.	H mm. H mm.	h mm. h mm.	B mm. B mm.	A mm. A mm.	α mm. α mm.	
PR 2.054	64,8	42	30	36,5	29,5	20	50	20°	
PR 2.055	73,8	48	35	42,0	34,0	23	57	20°	
PR 2.056	81,8	53	40	45,5	34,0	23	61	20°	
PR 2.058	92,8	59	45	54,0	41,0	30	68	20°	
PR 2.061	111,8	71	60	65,5	51,5	31	82	20°	
PR 2.062	127,8	80	60	67,8	51,5	37	92	20°	
PR 2.063	153,8	103	60	74,0	54,0	45	116	15°	

C = Dyn. Tragzahl Radiallager (ISO 281/1), C₀ = Stat. Tragzahl Radiallager (ISO 76),
F_r = Tragzahl Radiallager zulässige Belastung zwischen Rolle und Profil



Passende Anschraubplatten

Fitting flange plates

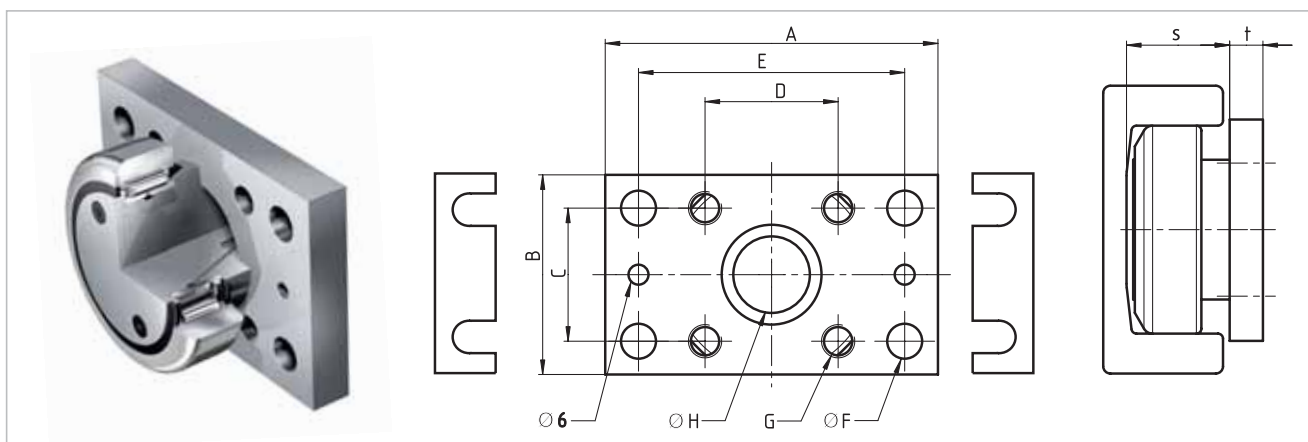

Typ Type	A	B	C	D	E	Ø F Ø F	G	Ø H Ø H	s	t	Distanzscheibe t=0,5mm Washer t=0.5mm	Distanzscheibe t=1,0mm Washer t=1.0mm
AP 0	100	60	40	40	80	10,5	M10	30	30,5	10	DS-0-0,5	DS-0-1,0
AP 1	120	80	50	50	90	12,5	M12	35	36,0	15	DS-1-0,5	DS-1-1,0
AP 2	120	80	50	50	90	12,5	M12	40	36,5	15	DS-2-0,5	DS-2-1,0
AP 3.1	160	100	60	60	120	17,0	M16	45	44,0	20	DS-3.1-0,5	DS-3.1-1,0
AP 4	180	120	80	80	140	17,0	M16	60	56,0	20	DS-4-0,5	DS-4-1,0
AP 6	200	150	100	100	160	17,0	M16	60	58,5	20	DS-6-0,5	DS-6-1,0

Anschraubplatten quadratisch Reihe AP-Q S. 74
Flange plates square series AP-Q page 74

Profile S. 56
Profiles page 56

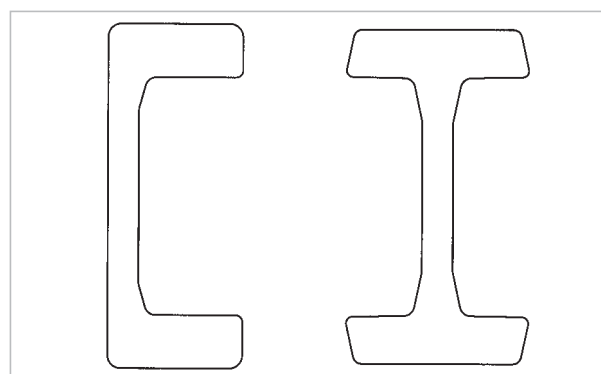
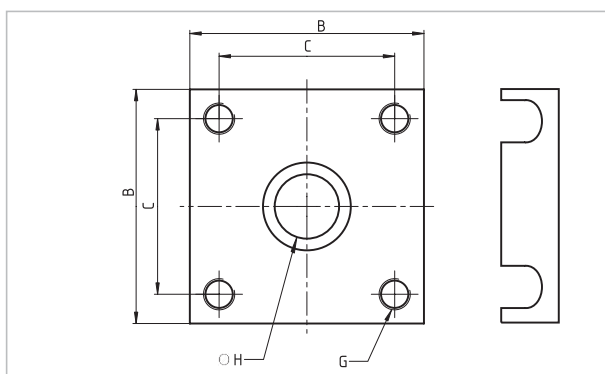

Bestellbeispiel | Order example

PR 2.054 [Radiallager] AP 0 [Anschraubplatte] DS-0-0,5 [Distanzscheibe] PR 0 Nb [Profil]
PR 2.054 [Radial Bearing] AP 0 [Flange plate] DS-0-0,5 [Washer type DS] PR 0 Nb [Profile]

Typ Type	F _R KN F _R KN	C KN C KN	C ₀ KN C ₀ KN	u/min max. r/pm max.	Gewicht kg Weight kg	Anschraubplatten Flange plates	Profile Profiles
PR 2.054	9,40	31,0	35,5	900	0,60	AP0 AP0-Q	PR 0 Nb
PR 2.055	11,30	45,5	51,0	900	0,90	AP1 AP1-Q	PR 1 Nb
PR 2.056	11,72	48,0	56,8	800	1,10	AP2 AP2-Q	PR 2 Nb
PR 2.058	20,47	68,0	72,0	750	1,80	AP3.1 AP3	PR 3 Nb
PR 2.061	21,68	81,0	95,0	650	3,05	AP4 AP4-Q	PR 4 Nb
PR 2.062	30,92	110,0	132,0	550	4,35	AP4 AP4-Q	PR 5 Nb
PR 2.063	54,02	151,0	192,0	450	7,10	AP6 AP6-Q	PR 6 Nb

C = Dynamic load capacity radial bearing (ISO 281/1), C₀ = Static load capacity radial bearing (ISO 76),
F_R = Load capacity radial bearing max. allowable force between bearing and profile,



Kombirollen | Combined Bearings

**Justierbare Kombirolleneinheit
Typ JC
für alle Standard-Profile**

Vorteile:

- Spielfreiheit zwischen Rolleneinheit und Profil.
- Höhere Positioniergenauigkeit.



**Adjustable Combined Bearing unit
Type JC
for all standard profiles**

Advantages:

- Min. clearance between bearing unit and profile.
- Higher positioning accuracy.

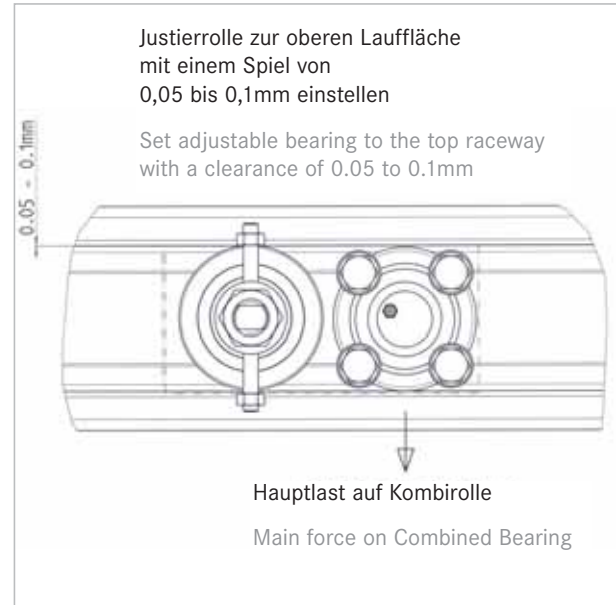

Einbau/Einstellung

- Die Einheit wird über die Flanschplatte angeschraubt
- Die Position der Justierrolle muß an der entgegengesetzten Seite der Last sein. Die Hauptlast soll auf das Radiallager der Kombirolle eingeleitet werden.
- Das Justierlager wird eingestellt und anschließend gekontert.

Vorsicht: Es dürfen keine großen Anpresskräfte auf die Justierrolle kommen, sonst droht die Gefahr von hohen Vorspannkräften die zu Profilbeschädigungen führen können.

Tipp: Lassen Sie ein Spiel von 0,05 - 0,1 mm zwischen Justierrolle und Profil.

Test: Der Führungswagen soll sich ohne große Laufwiderstände bewegen können.

Assembly/Adjusting

- The unit will be assembled by the flange plate.
- The position of the adjustable bearing must be at the load opposite side. The main forces should be on the radial bearing of the Combined Bearing.
- The adjustable bearing will be adjusted and finally secured.

Attention: Avoid giving too high pay loads to the adjustable bearing. (Risk of profile wear out.)

Advice: Adjust the adjustable bearing with a clearance of 0.05 to 0.1 mm to the profile.

Test: The carriage should run smoothly in the profile without big resistance.

CAD Download in 2D/3D unter www.winkel.de

CAD download in 2D/3D at www.winkel.de

Typ Type	A A	B B	C C	D D	F F	G G	H H	I I	J J	K K	L L	M M	N N	O O
JC 4.054	140	60	40	0	M10	62,4	62,5	64,5	24	30,5	10	30	72,0	80
JC 4.055	170	80	50	0	M12	70,0	70,1	84,0	33	36,0	15	40	83,5	102
JC 4.056	170	80	50	0	M12	78,0	77,7	84,5	33	36,5	15	40	83,5	102
JC 4.058	195	120	90	6	M16	78,0	88,4	92,0	28	44,0	20	60	90,0	152
JC 4.061	240	120	80	4	M16	101,6	107,7	104,0	29	55,0	20	60	120,0	150
JC 4.062	240	120	80	11,5	M16	101,6	123,0	105,0	29	56,0	20	60	120,0	150
JC 4.063	265	150	100	24	M16	101,6	149,0	107,5	29	58,5	20	75	130,0	170

C = Dyn. Tragzahl Radiallager (ISO 281/1), C₀ = Stat. Tragzahl Radiallager (ISO 76), (Kombirolle)

C_A = Dyn. Tragzahl Axiallager (ISO 281/1), C_{0A} = Stat. Tragzahl Axiallager (ISO 76), (Kombirolle)

F_r = Tragzahl Radiallager zulässige Belastung zwischen Rolle und Profil,

F_A = Tragzahl Axiallager zulässige Belastung zwischen Rolle und Profil (Kombirolle)

Kombirollen | Combined Bearings

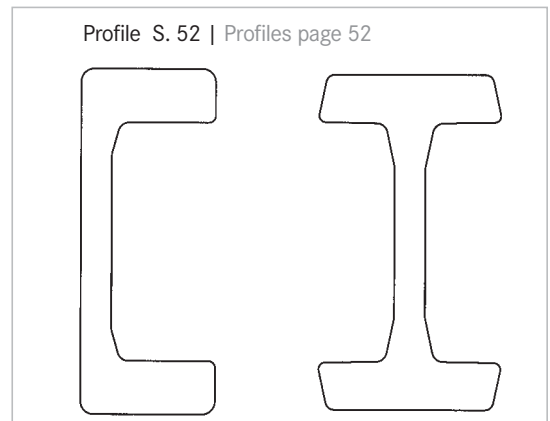
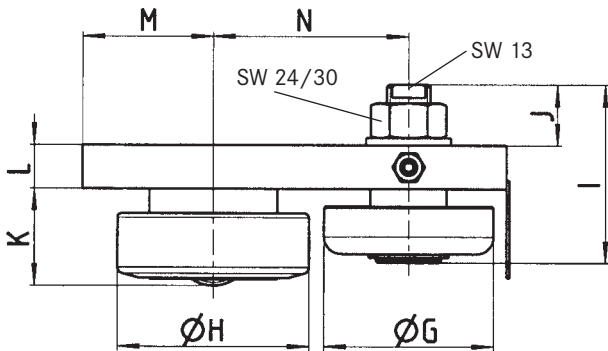
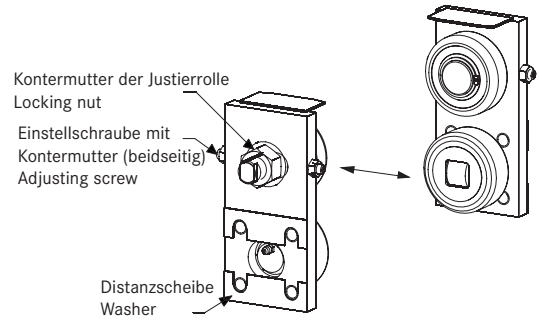
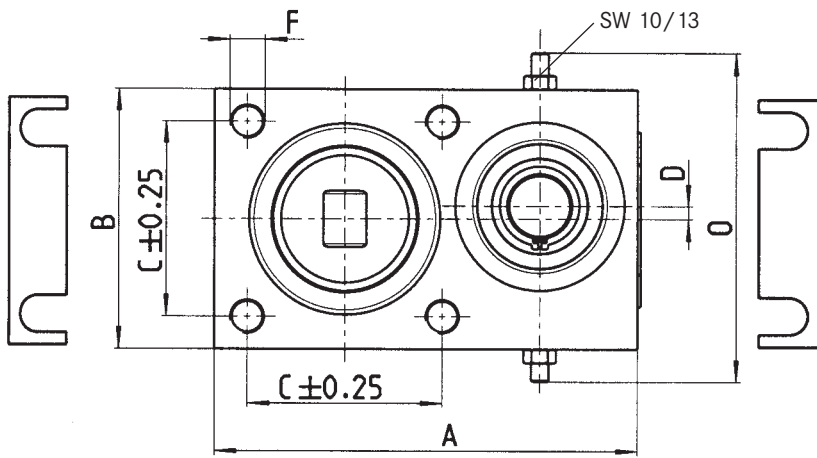
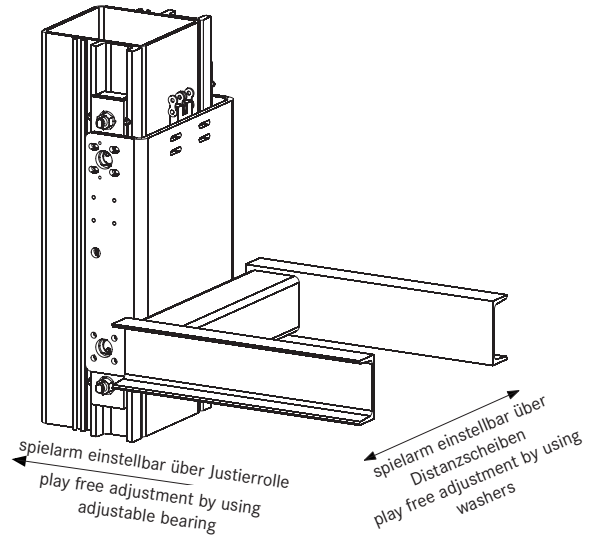
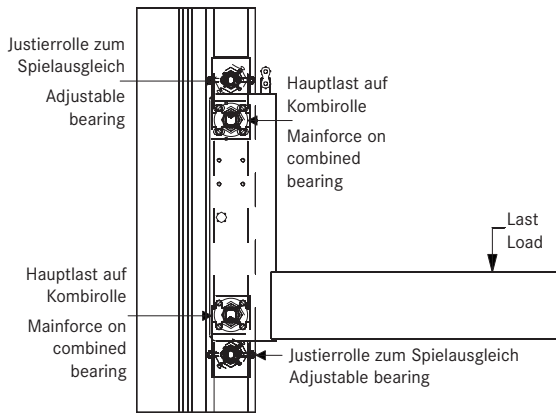

Bestellbeispiel | Order example

JC 4.054 [Kombirolle]
JC 4.054 [Combined Bearing]

Standard 0 [Profil]
Standard 0 [Profile]

DS-0-0,5 [Distanzscheibe]
DS-0-0,5 [Washer type DS]

Typ Type	F _R KN F _R KN	F _A KN F _A KN	C KN C KN	C ₀ KN C ₀ KN	C _A KN C _A KN	C _{0A} KN C _{0A} KN	u/min max. r/pm max.	Gewicht kg Weight kg	Profile Profiles
JC 4.054	9,40	3,1	31,0	35,5	11	11	900	1,65	0 Nb
JC 4.055	11,30	3,73	45,5	51,0	13	14	900	2,95	1 Nb
JC 4.056	11,72	3,87	48,0	56,8	18	18	800	3,3	2 Nb
JC 4.058	20,47	6,76	68,0	72,0	23	23	750	5,8	3 Nb
JC 4.061	21,68	7,16	81,0	95,0	31	36	650	8,75	4 Nb
JC 4.062	30,92	10,2	110,0	132,0	43	50	550	9,75	5 Nb
JC 4.063	54,02	17,8	151,0	192,0	68	71	450	13,9	6 Nb

C = Dynamic load capacity radial bearing (ISO 281/1), C₀ = Static load capacity radial bearing (ISO 76), (Combined Bearing)
 C_A = Dynamic load capacity axial bearing (ISO 281/1), C_{0A} = Static load capacity axial bearing (ISO 76), (Combined Bearing)
 F_R = Load capacity radial bearing max. allowable force between bearing and profile, (Combined Bearing)
 F_A = Load capacity axial bearing max. allowable force between bearing and profile, (Combined Bearing)



Kombirollen | Combined Bearings

Kombirolle mit Kombibolzen
Typ KB

Vorteile:

- universelle Befestigungsmöglichkeit
- wahlweise anschrauben oder anschweißen

Combined Bearing with combined bolt
Type KB

Advantages:

- free choice of bolt assembly
- the bolt can be welded or screwed to your design.



Scheiben der Stärke 0,5 und 1,0 mm sind auf Wunsch verfügbar.

CAD Download in 2D/3D unter www.winkel.de

Washers with 0.5 + 1.0 mm thickness are available if required.

CAD download in 2D/3D at www.winkel.de

Bestellbeispiel | Order example

KB 4.072 [Kombirolle]
KB 4.072 [Combined Bearing]

S-4.072-0,5 Distanzscheiben (Kombirolle)
S-4.072-0,5 Washer (Combined Bearing)

0 Nb [Profil]
0 Nb [Profile]

Typ Type	B B	A A	C C	D D	E E	F F	G G
KB 4.072	62,5	43,0	50	17,5	20	M 10x13	30
KB 4.073	70,1	55,0	60	25,5	23	M 12x18	40
KB 4.074	77,7	54,5	60	24,5	23	M 12x18	40
KB 4.076	88,4	68,0	70	31,0	30	M 14x20	44
KB 4.0784	107,7	75,0	80	36,0	31	M 14x22	54
KB 4.079	123,0	79,2	100	34,2	37	M 16x23	60
KB 4.080	149,0	89,0	120	29,0	45	M 16x23	80

C = Dyn. Tragzahl Radiallager (ISO 281/1), C₀ = Stat. Tragzahl Radiallager (ISO 76),
 C_A = Dyn. Tragzahl Axiallager (ISO 281/1), C_{0A} = Stat. Tragzahl Axiallager (ISO 76),
 F_R = Tragzahl Radiallager zulässige Belastung zwischen Rolle und Profil,
 F_A = Tragzahl Axiallager zulässige Belastung zwischen Rolle und Profil
 Maß A ohne Distanzscheiben; max. +2 mm

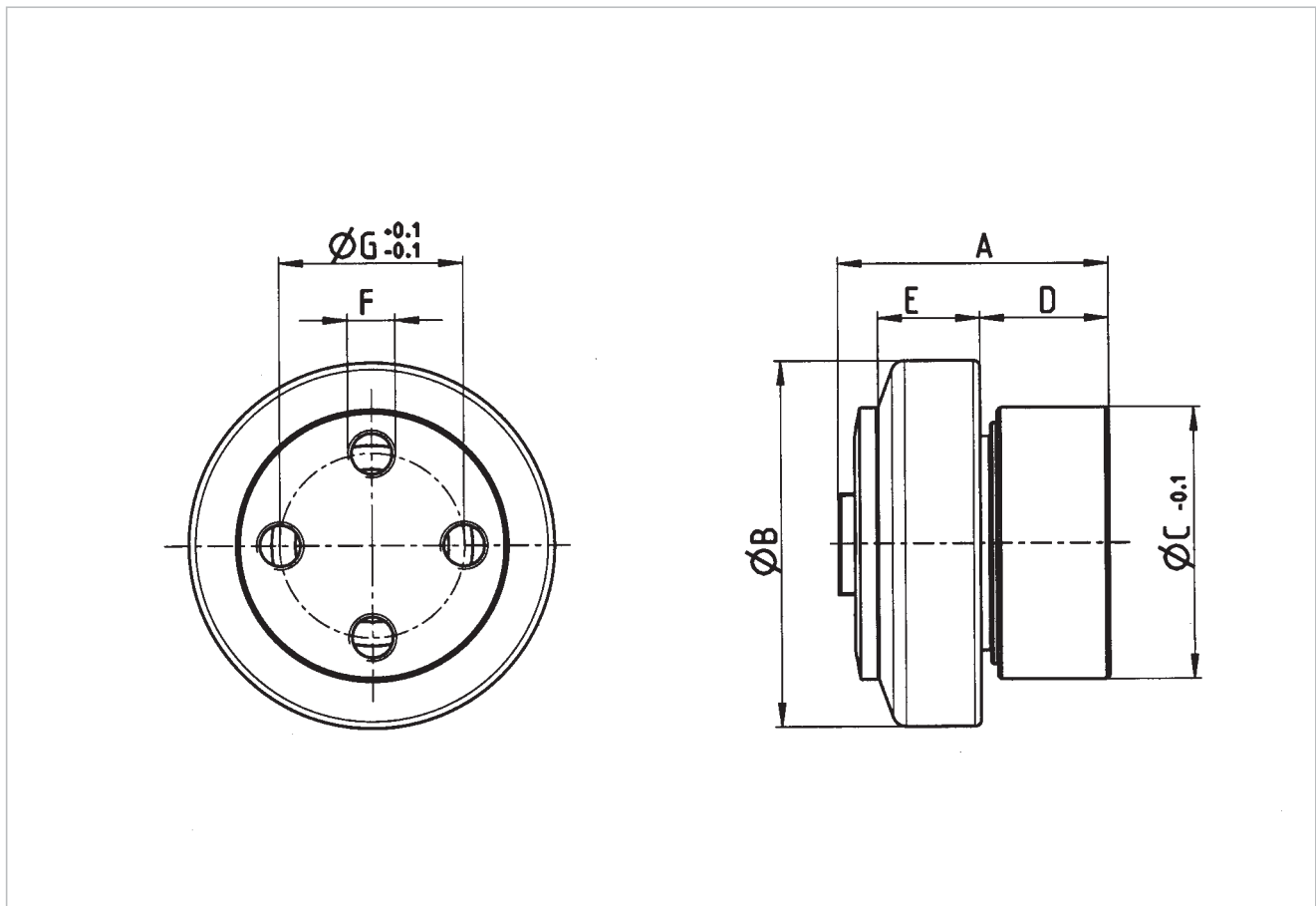
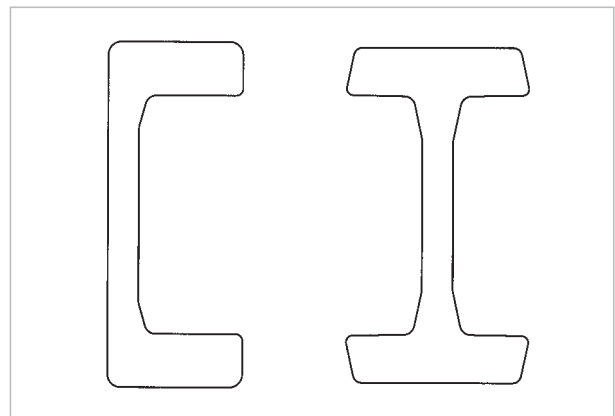
 Profile S. 52
 Profiles page 52

Typ Type	F_R KN F_R KN	F_A KN F_A KN	C KN C KN	C_0 KN C_0 KN	C_A KN C_A KN	C_{0A} KN C_{0A} KN	u/min max. r/pm max.	Gewicht kg Weight kg	Profile Profiles
KB 4.072	9,40	3,10	31,0	35,5	8	8	900	0,65	0 Nb
KB 4.073	11,30	3,73	45,5	51,0	14	14	800	1,10	1 Nb
KB 4.074	11,72	3,87	48,0	56,8	14	14	700	1,20	2 Nb
KB 4.076	20,47	6,76	68,0	72,0	15	15	600	2,05	3 Nb
KB 4.0784	21,68	7,16	81,0	95,0	31	36	500	3,20	4 Nb
KB 4.079	30,92	10,20	110,0	132,0	35	38	500	4,90	5 Nb
KB 4.080	37,81	17,80	151,0	192,0	68	71	400	8,00	6 Nb

C = Dynamic load capacity radial bearing (ISO 281/1), C_0 = Static load capacity radial bearing (ISO 76),
 C_A = Dynamic load capacity axial bearing (ISO 281/1), C_{0A} = Static load capacity axial bearing (ISO 76),
 F_R = Load capacity radial bearing max. allowable force between bearing and profile,
 F_A = Load capacity axial bearing max. allowable force between bearing and profile
 Dimension A without washers; max. 2 mm



Präzisions-Kombirolle mit Kombibolzen Typ KB PR

Vorteile:

- universelle Befestigungsmöglichkeit
- wahlweise anschrauben oder anschweißen

Precision Combined Bearing with combined bolt Type KB PR

Advantages:

- free choice of bolt assembly
- the bolt can be welded or screwed to your design.



Scheiben der Stärke 0,5 und 1,0 mm sind auf Wunsch verfügbar.

Washers with 0.5 + 1.0 mm thickness are available if required.

Bestellbeispiel | Order example

KB PR 4.072 [Kombirolle]

KB PR 4.072 [Combined Bearing]

S-4.072-0,5 Distanzscheiben (Kombirolle)

S-4.072-0,5 Washer (Combined Bearing)

PR 0 Nb [Profil]

PR 0 Nb [Profile]

Typ Type	B B	A A	C C	D D	E E	F F	G G
KB PR 4.072	64,8	43,0	50	17,5	20	M 10x13	30
KB PR 4.073	73,8	55,0	60	25,5	23	M 12x18	40
KB PR 4.074	81,8	54,5	60	24,5	23	M 12x18	40
KB PR 4.076	92,8	68,0	70	31,0	30	M 14x20	44
KB PR 4.0784	111,8	75,0	80	36,0	31	M 14x22	54
KB PR 4.079	127,8	79,2	100	34,2	37	M 16x23	60
KB PR 4.080	153,8	89,0	120	29,0	45	M 16x23	80

C = Dyn. Tragzahl Radiallager (ISO 281/1), C₀ = Stat. Tragzahl Radiallager (ISO 76),

C_A = Dyn. Tragzahl Axiallager (ISO 281/1), C_{0A} = Stat. Tragzahl Axiallager (ISO 76),

F_R = Tragzahl Radiallager zulässige Belastung zwischen Rolle und Profil,

F_A = Tragzahl Axiallager zulässige Belastung zwischen Rolle und Profil

Maß A ohne Distanzscheiben; max. +2 mm

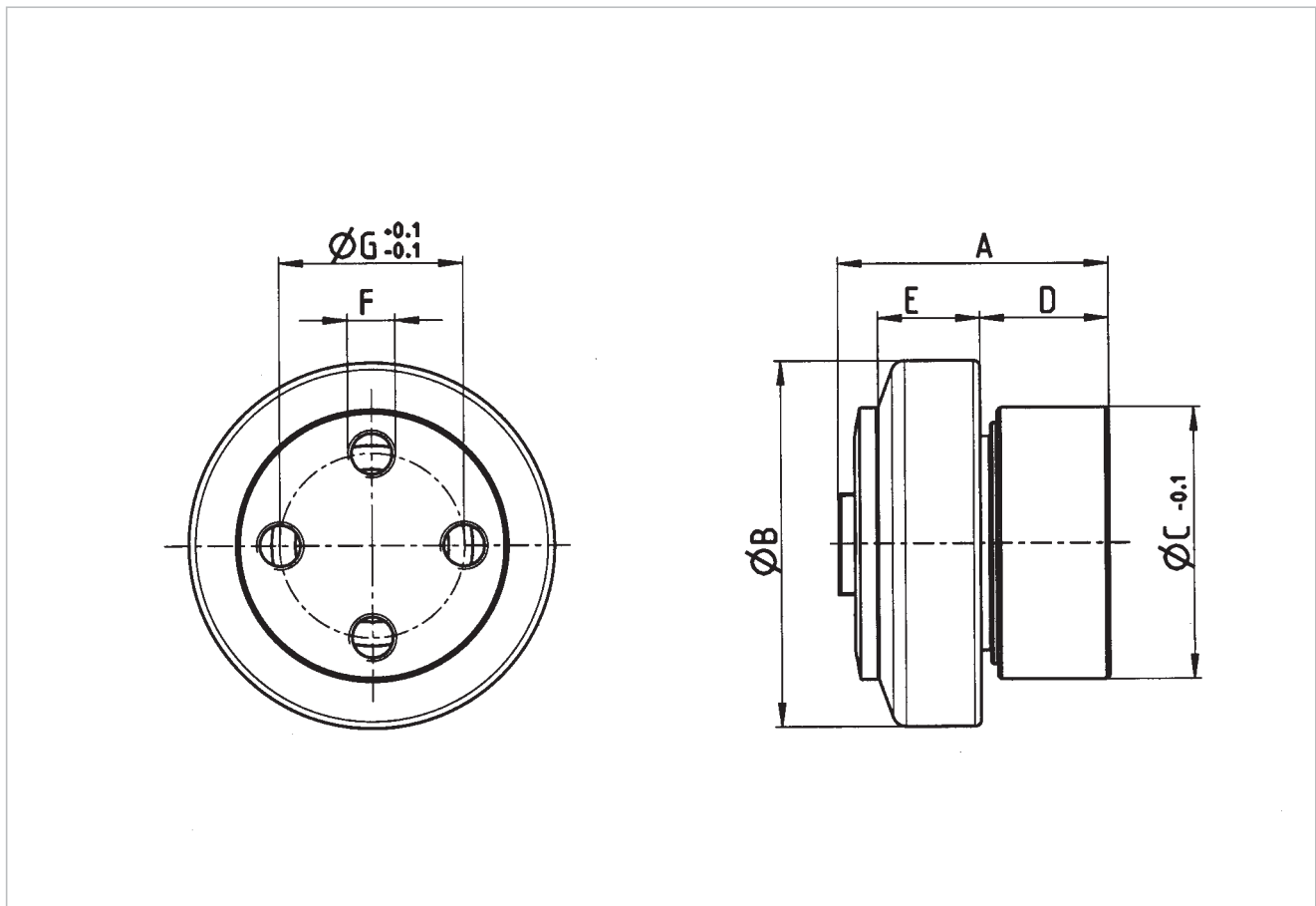
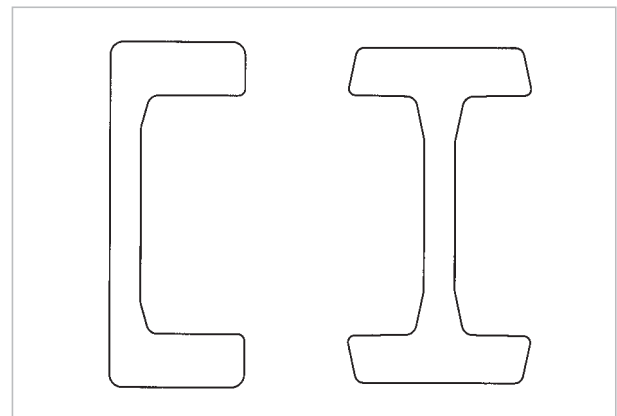
 Profile S. 56
 Profiles page 56

Typ Type	F_R KN F_R KN	F_A KN F_A KN	C KN C KN	C_0 KN C_0 KN	C_A KN C_A KN	C_{0A} KN C_{0A} KN	u/min max. r/pm max.	Gewicht kg Weight kg	Profile Profiles
KB PR 4.072	9,40	3,10	31,0	35,5	8	8	900	0,68	PR 0 Nb
KB PR 4.073	11,30	3,73	45,5	51,0	14	14	800	1,15	PR 1 Nb
KB PR 4.074	11,72	3,87	48,0	56,8	14	14	700	1,30	PR 2 Nb
KB PR 4.076	20,47	6,76	68,0	72,0	15	15	600	2,13	PR 3 Nb
KB PR 4.0784	21,68	7,16	81,0	95,0	31	36	500	3,34	PR 4 Nb
KB PR 4.079	30,92	10,20	110,0	132,0	35	38	500	5,10	PR 5 Nb
KB PR 4.080	37,81	17,80	151,0	192,0	68	71	400	8,30	PR 6 Nb

C = Dynamic load capacity radial bearing (ISO 281/1), C_0 = Static load capacity radial bearing (ISO 76),
 C_A = Dynamic load capacity axial bearing (ISO 281/1), C_{0A} = Static load capacity axial bearing (ISO 76),
 F_R = Load capacity radial bearing max. allowable force between bearing and profile,
 F_A = Load capacity axial bearing max. allowable force between bearing and profile
 Dimension A without washers; max. 2 mm



Kombirollen | Combined Bearings

Kombirolle mit Kombibolzen und Oilamid* Einsatz
Typ KB P

Combined Bearing with combined bolt and oilamid* insert
Type KB P

Vorteile:

- universelle Befestigungsmöglichkeit
- wahlweise anschrauben oder anschweißen

Advantages:

- free choice of bolt assembly
- the bolt can be welded or screwed to your design



*Oilamid ist ein hochabriebfester, selbstschmierender Polyamid.
Scheiben der Stärke 0,5 und 1,0 mm sind auf Wunsch verfügbar.

*Oilamid is a high resistant, self lubricant polyamide.
Washers with 0.5 + 1.0 mm thickness are available if required.

Bestellbeispiel | Order example

KB 4.072 P [Kombirolle]

KB 4.072 P [Combined Bearing]

S-4.072-0,5 Distanzscheiben (Kombirolle)

S-4.072-0,5 Washer (Combined Bearings)

0 Nb [Profil]

0 NB [Profile]

Typ Type	B B	A A	C C	D D	E E	F F	G G
KB 4.072 P	62,5	43,0	50	17,5	20	M 10x13	30
KB 4.073 P	70,1	55,0	60	25,5	23	M 12x18	40
KB 4.074 P	77,7	54,5	60	24,5	23	M 12x18	40
KB 4.076 P	88,4	68,0	70	31,0	30	M 14x20	44
KB 4.0784 P	107,7	75,0	80	36,0	31	M 14x22	54
KB 4.079 P	123,0	79,2	100	34,2	37	M 16x23	60
KB 4.080 P	149,0	89,0	120	29,0	45	M 16x23	80

C = Dyn. Tragzahl Radiallager (ISO 281/1), C₀ = Stat. Tragzahl Radiallager (ISO 76),
F_r = Tragzahl Radiallager zulässige Belastung zwischen Rolle und Profil,
F_A = Tragzahl Axiallager zulässige Belastung zwischen Rolle und Profil
Maß A ohne Distanzscheiben; max. +2 mm

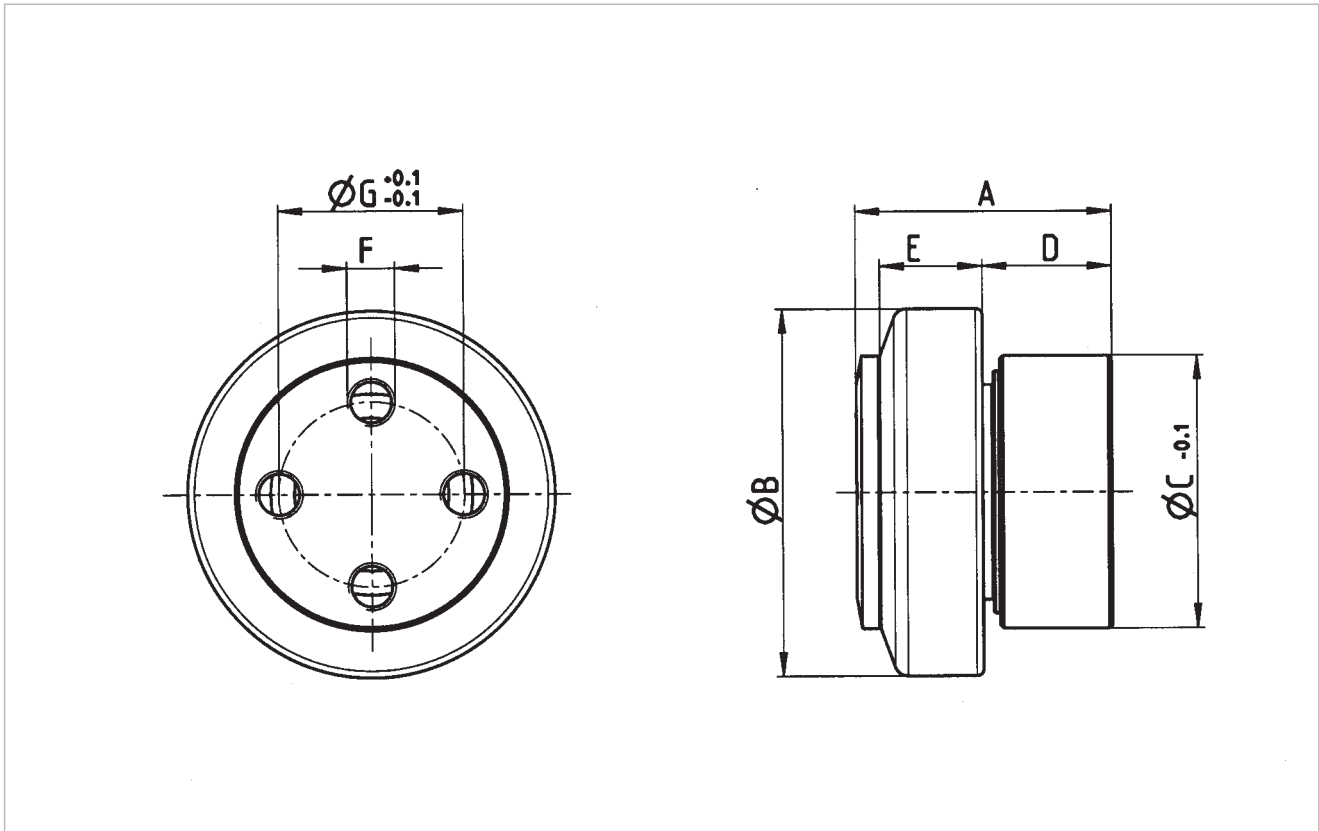

Hinweis: Bei hoher axialer Belastung ist eine Bearbeitung der Gleitfläche zu empfehlen.

Notice: At high axial forces we recommend to mill the axial raceway of the profile.

Profile S. 52
Profiles page 52

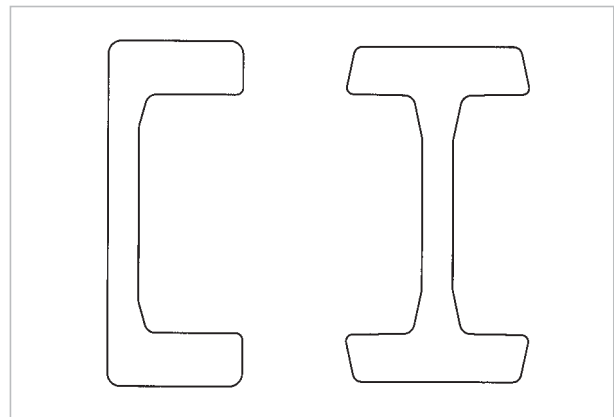
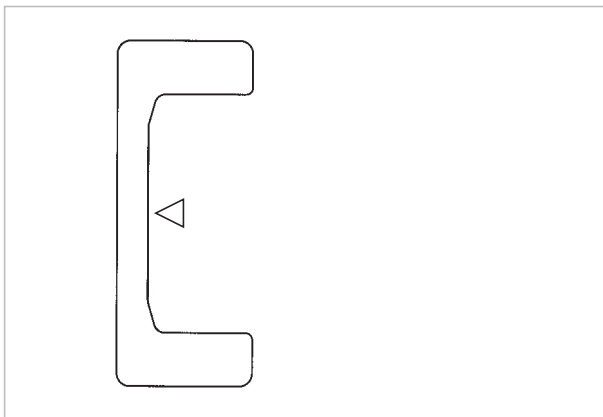

Typ Type	F_R KN F_R KN	F_A KN F_A KN	C KN C KN	C_0 KN C_0 KN	u/min max. r/pm max.	Gewicht kg Weight kg	Profile Profiles
KB 4.072 P	9,40	4,0	31,0	35,5	900	0,53	0 Nb
KB 4.073 P	11,30	6,7	45,5	51,0	800	1,00	1 Nb
KB 4.074 P	11,72	7,2	48,0	56,8	700	1,10	2 Nb
KB 4.076 P	20,47	8,9	68,0	72,0	600	1,93	3 Nb
KB 4.0784 P	21,68	14,4	81,0	95,0	500	3,00	4 Nb
KB 4.079 P	30,92	38,4	110,0	132,0	500	4,72	5 Nb
KB 4.080 P	37,81	41,6	151,0	192,0	400	7,80	6 Nb

C = Dynamic load capacity radial bearing (ISO 281/1), C_0 = Static load capacity radial bearing (ISO 76),
 F_R = Load capacity radial bearing max. allowable force between bearing and profile,
 F_A = Load capacity axial bearing max. allowable force between bearing and profile
 Dimension A without washers; max. 2 mm



Kombirollen | Combined Bearings

Präzisions-Kombirolle mit Kombibolzen und Oilamid* Einsatz
Typ KB PR P

Precision Combined Bearing with combined bolt and oilamid* insert
Type KB PR P

Vorteile:

- universelle Befestigungsmöglichkeit
- wahlweise anschrauben oder anschweißen

Advantages:

- free choice of bolt assembly
- the bolt can be welded or screwed to your design



*Oilamid ist ein hochabriebfester, selbstschmierender Polyamid.
Scheiben der Stärke 0,5 und 1,0 mm sind auf Wunsch verfügbar.

*Oilamid is a high resistant, self lubricant polyamide.
Washers with 0.5 + 1.0 mm thickness are available if required.

Bestellbeispiel | Order example

KB PR 4.072 P [Kombirolle] S-4.072-0,5 Distanzscheiben (Kombirolle) PR 0 Nb [Profil]
KB PR 4.072 P [Combined Bearing] S-4.072-0,5 Washer (Combined Bearings) PR 0 NB [Profile]

Typ Type	B B	A A	C C	D D	E E	F F	G G
KB PR 4.072 P	64,8	43,0	50	17,5	20	M 10x13	30
KB PR 4.073 P	73,8	55,0	60	25,5	23	M 12x18	40
KB PR 4.074 P	81,8	54,5	60	24,5	23	M 12x18	40
KB PR 4.076 P	92,8	68,0	70	31,0	30	M 14x20	44
KB PR 4.0784 P	111,8	75,0	80	36,0	31	M 14x22	54
KB PR 4.079 P	127,8	79,2	100	34,2	37	M 16x23	60
KB PR 4.080 P	153,8	89,0	120	29,0	45	M 16x23	80

C = Dyn. Tragzahl Radiallager (ISO 281/1), C₀ = Stat. Tragzahl Radiallager (ISO 76),
F_r = Tragzahl Radiallager zulässige Belastung zwischen Rolle und Profil,
F_A = Tragzahl Axiallager zulässige Belastung zwischen Rolle und Profil
Maß A ohne Distanzscheiben; max. +2 mm

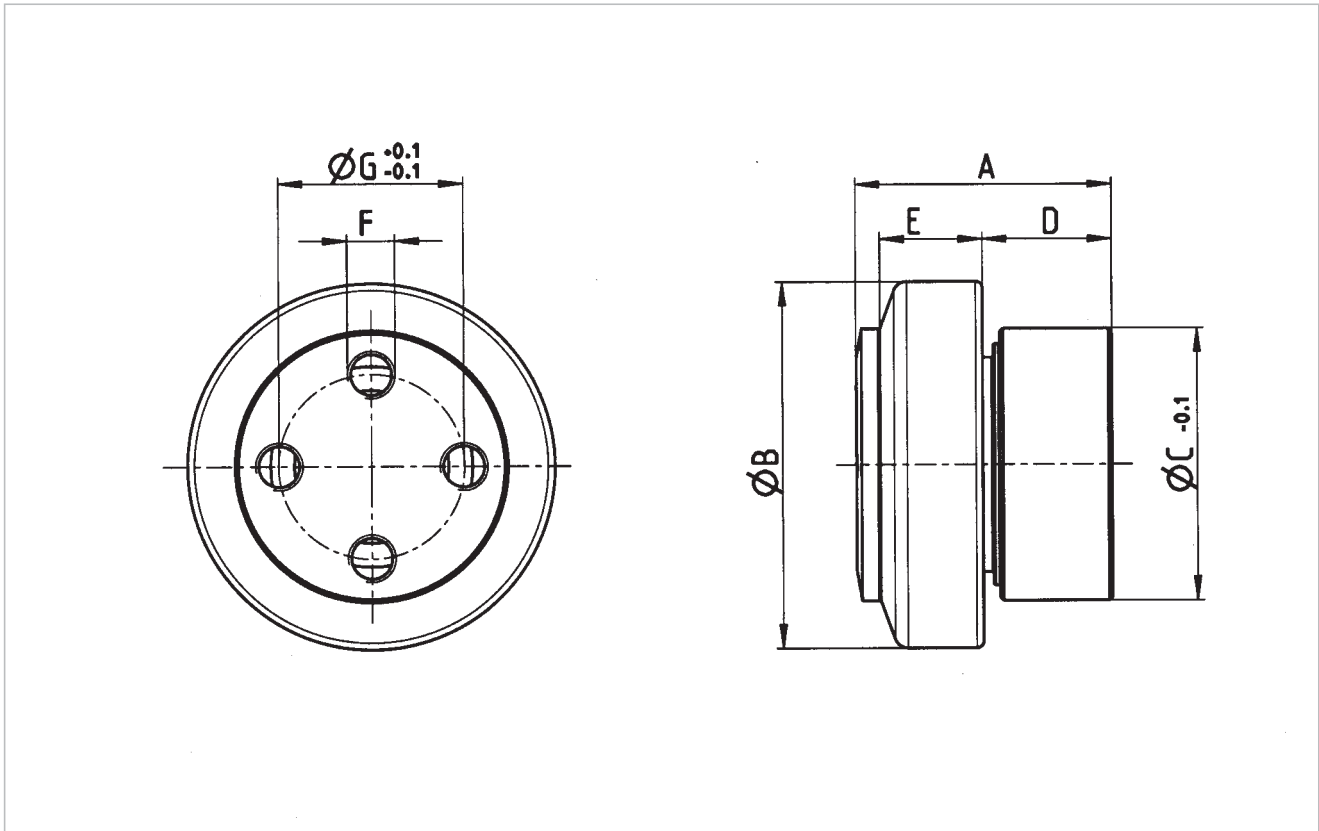

Hinweis: Bei hoher axialer Belastung ist eine Bearbeitung der Gleitfläche zu empfehlen.

Notice: At high axial forces we recommend to mill the axial raceway of the profile.

Profile S. 56
Profiles page 56

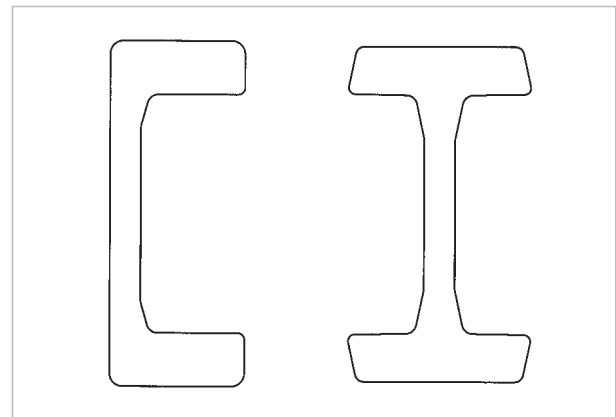
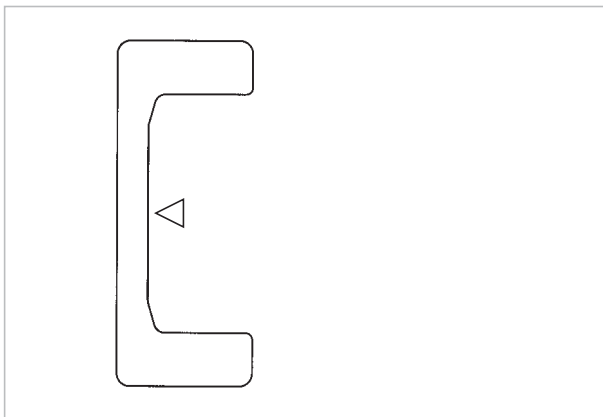

Typ Type	F_R KN F_R KN	F_A KN F_A KN	C KN C KN	C_0 KN C_0 KN	u/min max. r/pm max.	Gewicht kg Weight kg	Profile Profiles
KB PR 4.072 P	9,40	3,0	31,0	35,5	900	0,56	PR 0 Nb
KB PR 4.073 P	11,30	6,7	45,5	51,0	800	1,05	PR 1 Nb
KB PR 4.074 P	11,72	7,2	48,0	56,8	700	1,20	PR 2 Nb
KB PR 4.076 P	20,47	8,9	68,0	72,0	600	2,00	PR 3 Nb
KB PR 4.0784 P	21,68	14,4	81,0	95,0	500	3,14	PR 4 Nb
KB PR 4.079 P	30,92	38,4	110,0	132,0	500	4,90	PR 5 Nb
KB PR 4.080 P	37,81	41,6	151,0	192,0	400	8,10	PR 6 Nb

C = Dynamic load capacity radial bearing (ISO 281/1), C_0 = Static load capacity radial bearing (ISO 76),
 F_R = Load capacity radial bearing max. allowable force between bearing and profile,
 F_A = Load capacity axial bearing max. allowable force between bearing and profile
 Dimension A without washers; max. 2 mm



Standard Nb-Profile

- Alle Profile sind ab Standard 0 aus hochwertigem Stahl in S355 J2G3 Nb (St 52.3 Nb) gefertigt und sandgestrahlt. $L_{\max} = 12$ m.
- Passend zu unserem Kombirollensystem liefern wir alle Profiltypen in Fixlängen sofort ab Lager.
- Auf Wunsch sind alle Profile in feingerichteter Ausführung erhältlich.
- Höhere Tragkräfte durch neue Nb-Serie.
- **Komplette Profilmbearbeitung nach Kundenzeichnungen auf Anfrage.**

CAD Download in 2D/3D unter www.winkel.de



Standard Nb-profiles

- All profiles from Standard 0 on are made from high-quality steel UNI FE 510.C Nb, in sandblasted version. $L_{\max} = 12$ m.
- To our Combined Bearing system, we deliver all profiles in fixed lengths, immediately from stock.
- All profiles are available in fine straightened style on request.
- Higher load capacity with new Nb-series.
- **Machined profiles according to customer drawings on request.**

CAD download in 2D/3D at www.winkel.de



Standard A

- Gewicht/m: 2,62 kg
Weight/meter
- Wx: 4,38 cm³
- Wy: 1,07 cm³
- ix: 0,31 cm
- ey: 0,78 cm
- Ix: 10,6 cm⁴
- Iy: 1,73 cm⁴
- iy: 0,05 cm

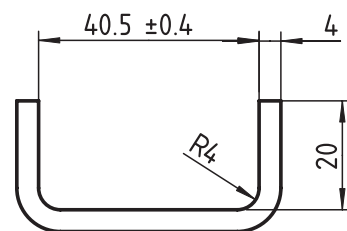

$L_{\max} = 6$ m

Standard S

- Gewicht/m: 5,3 kg
Weight/meter
- Wx: 11,9 cm³
- Wy: 2,5 cm³
- ix: 2,4 cm
- ey: 0,94 cm
- Ix: 38,8 cm⁴
- Iy: 5,2 cm⁴
- iy: 0,8 cm

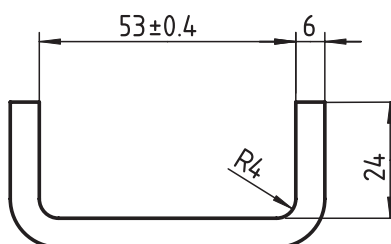

$L_{\max} = 8$ m

Hinweis: Feingerichtete Profile weisen eine Geradheit von $\pm 0,3$ mm/lfm. auf. Standard $\pm 1,0$ mm/lfm.
 Notice: The straightness for fine straightened profiles is $\pm 0,3$ mm per meter. Standard $\pm 1,0$ per meter



Kombirollen | Combined bearings

Standard 0 Nb

■ Gewicht/m:	10,5 kg
Weicht/meter	
■ Wx:	32 cm ³
■ Wy:	6 cm ³
■ ix:	3,2 cm
■ ey:	1,3 cm
■ lx:	137 cm ⁴
■ ly:	15 cm ⁴
■ iy:	1,0 cm

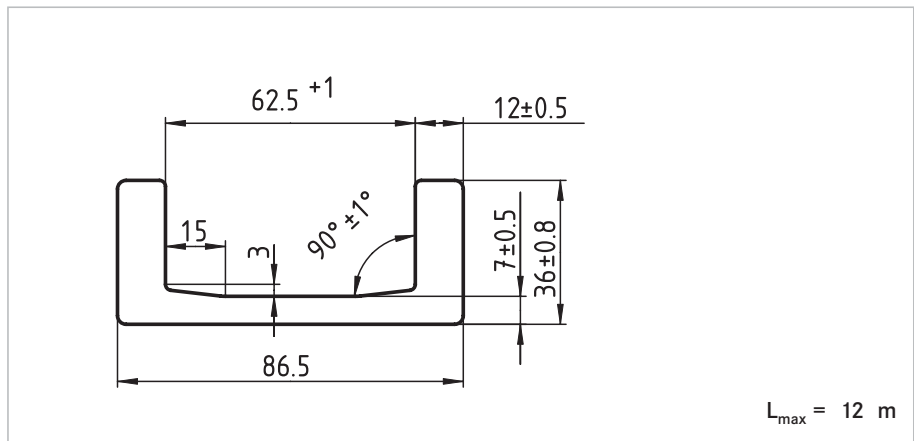

Standard 1 Nb

■ Gewicht/m:	14,8 kg
Weicht/meter	
■ Wx:	53 cm ³
■ Wy:	11 cm ³
■ ix:	3,8 cm
■ ey:	1,5 cm
■ lx:	273 cm ⁴
■ ly:	27 cm ⁴
■ iy:	1,2 cm

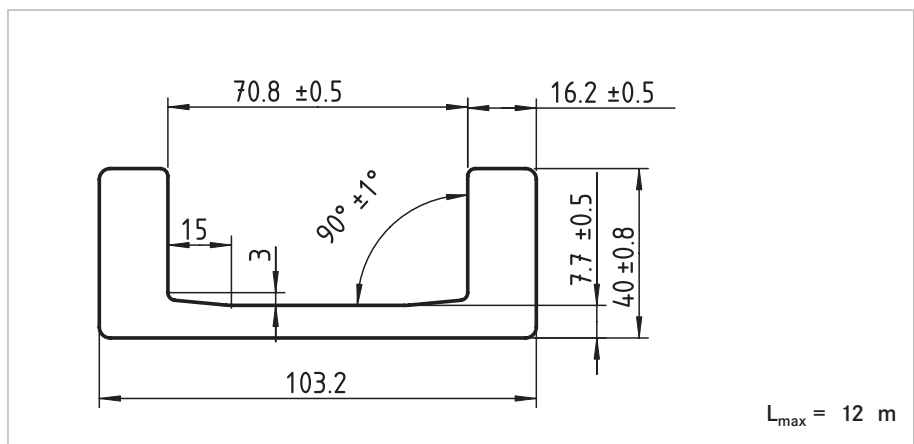

Standard 2 Nb

■ Gewicht/m:	20,9 kg
Weicht/meter	
■ Wx:	81 cm ³
■ Wy:	15 cm ³
■ ix:	4,3 cm
■ ey:	1,5 cm
■ lx:	493 cm ⁴
■ ly:	38 cm ⁴
■ iy:	1,2 cm

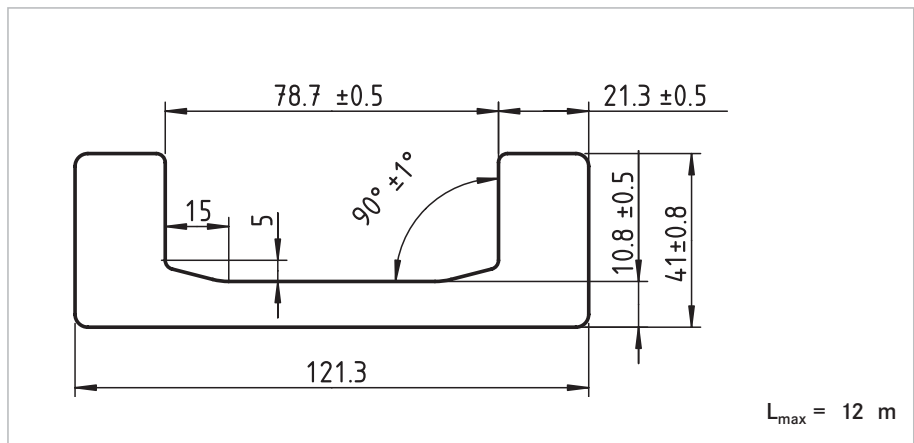

Standard 3 Nb

■ Gewicht/m:	28,6 kg
Weicht/meter	
■ Wx:	128 cm ³
■ Wy:	27 cm ³
■ ix:	4,8 cm
■ ey:	2,0 cm
■ lx:	865 cm ⁴
■ ly:	89 cm ⁴
■ iy:	1,5 cm

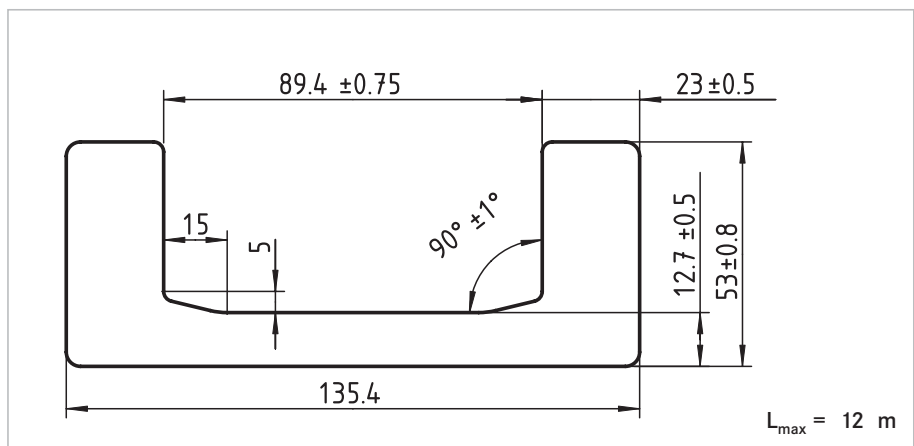



Kombirollen | Combined bearings

Standard 4 Nb

- Gewicht/m: 36,0 kg
Weight/meter
- Wx: 190 cm³
- Wy: 39 cm³
- ix: 5,7 cm
- ey: 2,2 cm
- lx: 1494 cm⁴
- ly: 150 cm⁴
- iy: 1,8 cm

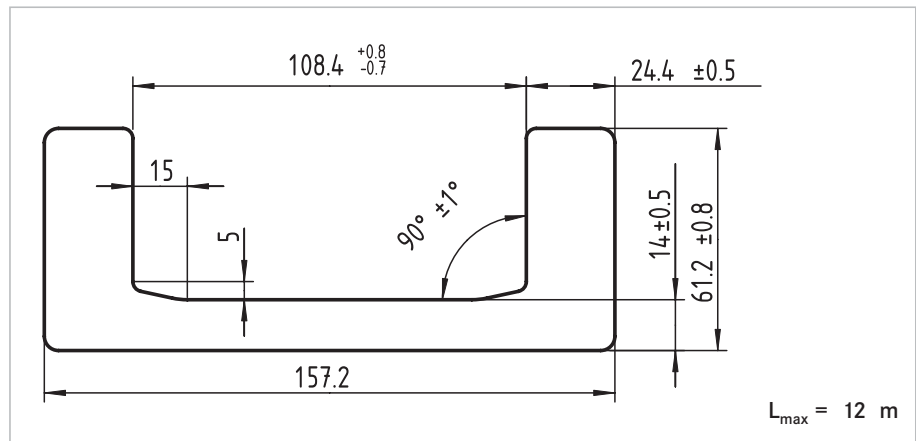

Standard 5 Nb

- Gewicht/m: 42,8 kg
Weight/meter
- Wx: 250 cm³
- Wy: 48 cm³
- ix: 6,3 cm
- ey: 1,9 cm
- lx: 2185 cm⁴
- ly: 205 cm⁴
- iy: 1,9 cm

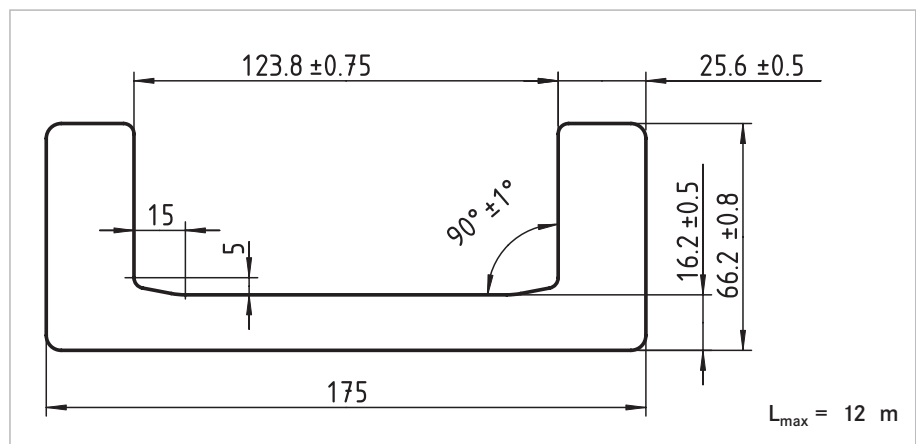

Standard 6 Nb

- Gewicht/m: 52,3 kg
Weight/meter
- Wx: 340 cm³
- Wy: 57 cm³
- ix: 7,1 cm
- ey: 2,0 cm
- lx: 3423 cm⁴
- ly: 270 cm⁴
- iy: 2,0 cm

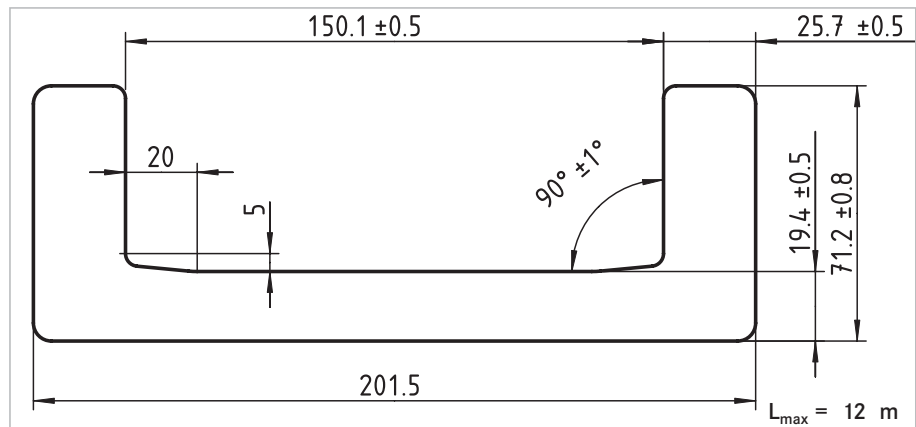

NEU
NEW

Standard 8 Nb

- Gewicht/m: 78,75 kg
Weight/meter
- Wx: 681,61 cm³
- Wy: 125,14 cm³
- ix: 9,27 cm
- ey: 2,68 cm
- lx: 8605,37 cm⁴
- ly: 721,54 cm⁴
- iy: 2,68 cm

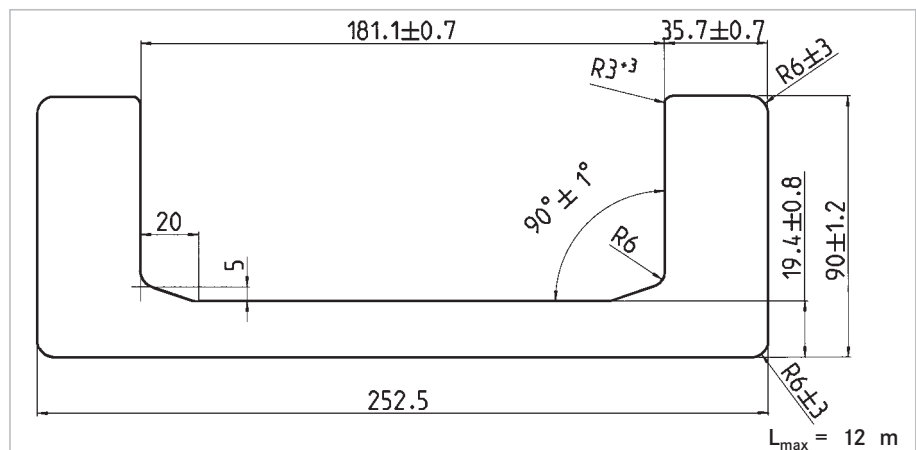

Hinweis: Feingerichtete Profile weisen eine Geradheit von ± 0,3 mm/lfm. auf. Standard ± 1,0 mm/lfm.
Notice: The straightness for fine straightened profiles is ± 0,3 mm per meter. Standard ± 1,0 mm per meter



Kombirollen | Combined bearings

**WINKEL U-Profile
mit 30% höherer Tragkraft**

- Höhere Tragkraft bei gleichen Abmessungen durch Niobium-Stahl S355 J2G3 Nb (St 52.3 Nb)
- Auswahl eventuell kleinerer Baugrößen (Kostenvorteil)
- Höhere Verschleißfestigkeit gegen Auswalzen bei Überlastungen

**WINKEL U-Profiles
with 30% increased load capacity**

- higher load capacity at same sizes by using profiles with steelgrade UNI FE 510.C Nb
- choice of smaller sizes (price advantage)
- higher resistance against wear out effects

**Vergleich S355 J2G3 - S355 J2G3 Nb
(St 52.3 - St 52.3 Nb)**

Comparison UNI FE 510.C - UNI FE 510.C Nb

Merkmal Characteristic	S355 J2G3 (St 52.3) (alt) UNI FE 510.C (old)	S355 J2G3 Nb (St 52.3 Nb) neu UNI FE 510.C Nb new
Streckgrenze 1 Yield point 1	min 355 N/mm ²	min 420 N/mm ²
Streckgrenze 2 Yield point 2	min 345 N/mm ²	min 400 N/mm ²
Zugfestigkeit Tensile strength	490 - 630 N/mm ²	540 - 670 N/mm ²
Bruchdehnung Elongation	min 22%	min 20%
max. zul. Hertz'sche Pressung max. hertzian pressure	750 N/mm ²	860 N/mm ²

Hinweis: Streckgrenze 1 gilt für Flanschdicken < 16 mm, Streckgrenze 2 gilt für Flanschdicken ab 16 mm.
Notice: Yield point 1 is only valid for flange thickness < 16 mm, yield point 2 is only valid for flange thickness > 16 mm.

Bedingt durch eine Mikrolegierung mit Niobium weist der Stahl S355 J2G3 Nb (St.52.3 Nb) höhere Festigkeitseigenschaften und ein feinkörnigeres Gefüge auf als der herkömmliche Stahl S355 J2G3 (St.52.3). Daraus resultiert u.a. ein besseres Schweißverhalten und eine höhere Sprödbrechtsicherheit. Die damit verbundene höhere Flächenpressung zeigt die nachfolgende Grafik.

Caused by micro alloying with niobium, the steelgrade UNI FE 510.C Nb has a higher tensile and yield strength and a more fine grained structure than a conventional UNI FE 510.C steelgrade. Thus the steelgrade UNI FE 510.C Nb has a better weldability and a higher resistance to brittle fracture. The higher bearing pressure of UNI FE 510.C Nb in comparison to UNI FE 510.C is shown by the figure below.

**Rollendrucke für Radiallager
im Vergleich:**

**Bearing pressures for radial bearings
in comparison:**

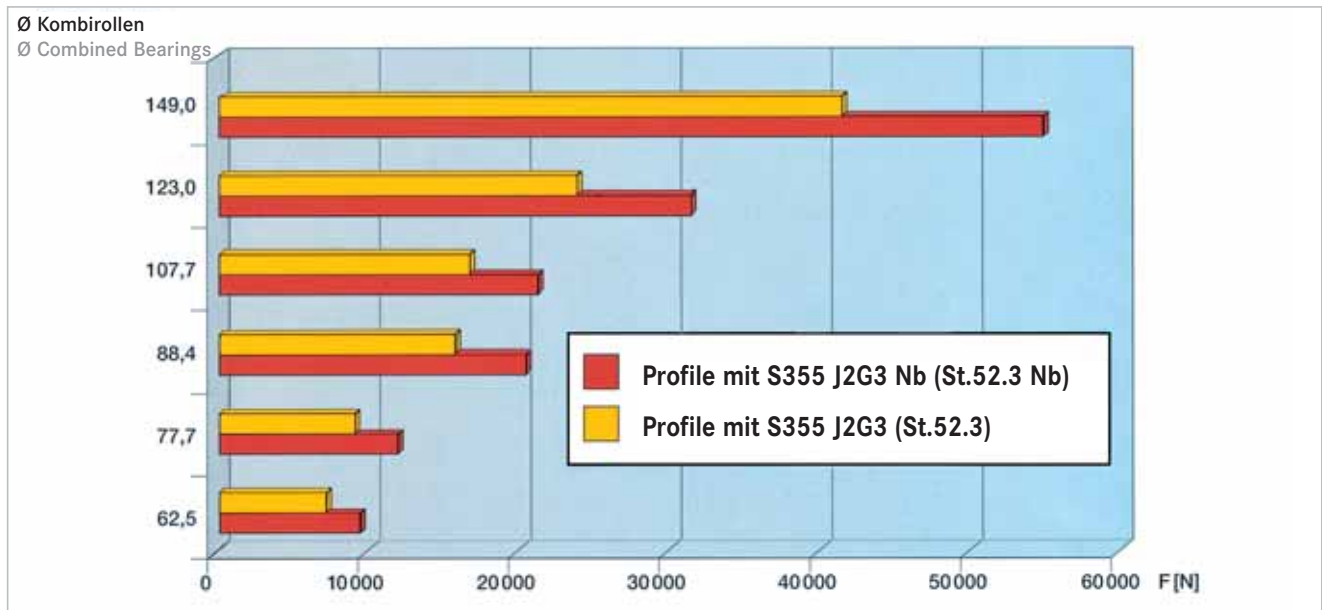



Präzisions-Profile Typ PR

- Alle Profile sind aus hochwertigem Stahl in S355 J2G3 Nb (St 52.3 Nb) gefertigt und sandgestrahlt.
- Passend zu unserem Kombirollensystem liefern wir alle Profiltypen in Fixlängen.
- Profile in feingerichteter Ausführung.
- Maximale Produktionslänge 12 m.
- Geringe Lagerluft zwischen Laufrolle und Profil.
- Höhere Tragkräfte durch neue Nb-Serie.
- **Komplette Profilbearbeitung nach Kundenzeichnungen auf Anfrage.**

Precision profiles type PR

- All profiles are made from high-quality steel UNI FE 510.C Nb, in sandblasted version.
- To our Combined Bearing system, we deliver all profiles in fixed lengths.
- All profiles are fine straightened.
- Maximum production length 12 m.
- Min clearance between bearing and profile.
- Higher load capacity with new Nb-series.
- **Machined profiles according to customer drawings on request.**

PR 0 Nb

- Gewicht /m: 9,4 kg
Weight/meter
- Wx: 24 cm³
- Wy: 6 cm³
- ey: 1,23 cm
- lx: 126 cm⁴
- ly: 13 cm⁴

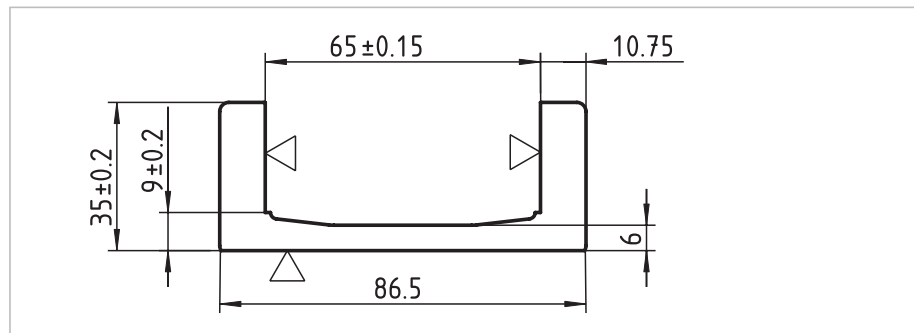

PR 1 Nb

- Gewicht/m: 13,4 kg
Weight/meter
- Wx: 41 cm³
- Wy: 10 cm³
- ey: 1,43 cm
- lx: 255 cm⁴
- ly: 25 cm⁴

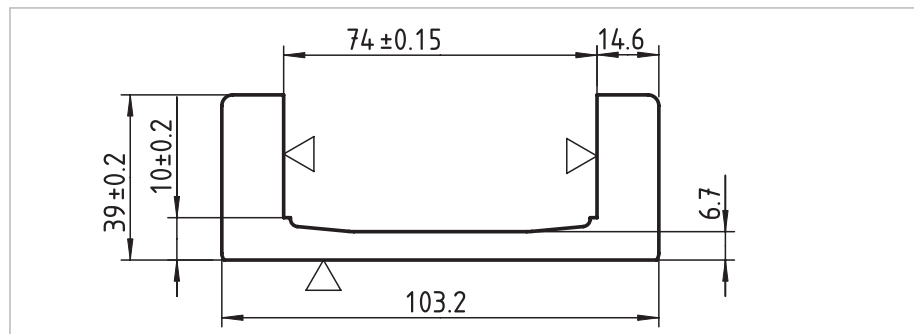

PR 2 Nb

- Gewicht/m: 17,8 kg
Weight/meter
- Wx: 63 cm³
- Wy: 13 cm³
- ey: 1,47 cm
- lx: 449 cm⁴
- ly: 36 cm⁴

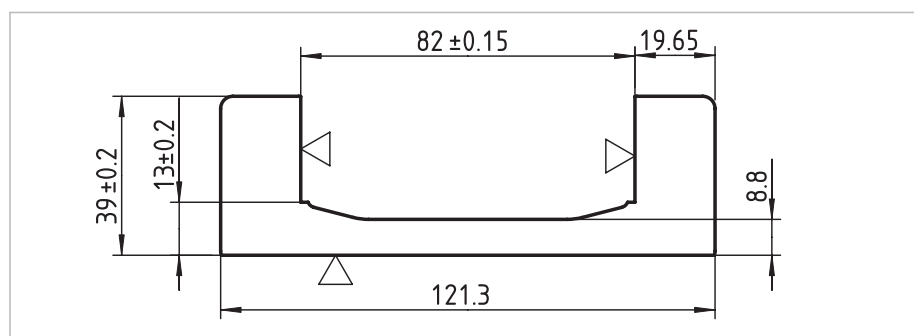

PR 3 Nb

- Gewicht/m: 24,9 kg
Weight/meter
- Wx: 99 cm³
- Wy: 25 cm³
- ey: 1,92 cm
- lx: 795 cm⁴
- ly: 80 cm⁴

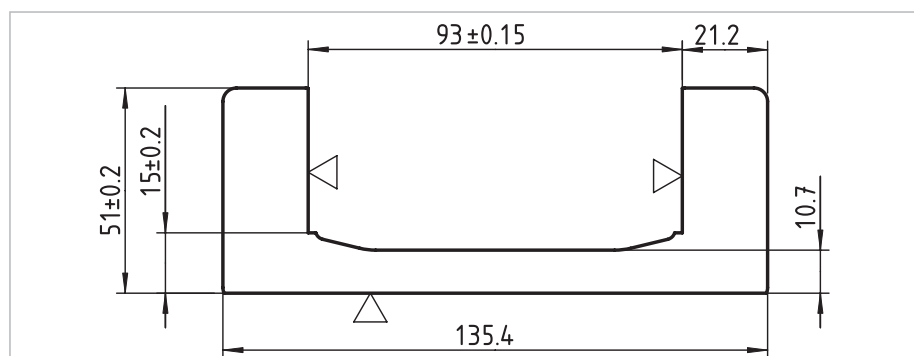



Kombirollen | Combined bearings

PR 4 Nb

- Gewicht/m: 32,1 kg
Weight/meter
- Wx: 148 cm³
- Wy: 37 cm³
- ey: 2,15 cm
- Ix: 1382 cm⁴
- Iy: 138 cm⁴

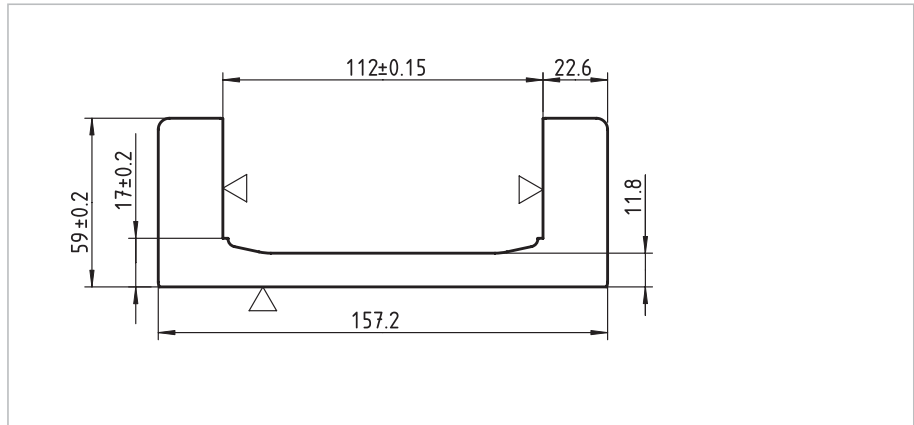

PR 5 Nb

- Gewicht/m: 36,3 kg
Weight/meter
- Wx: 188 cm³
- Wy: 45 cm³
- ey: 2,31 cm
- Ix: 1980 cm⁴
- Iy: 195 cm⁴

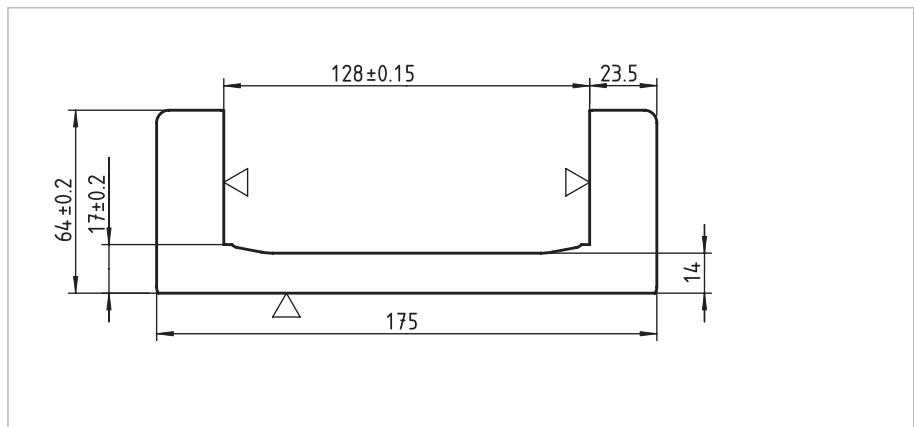

PR 6 Nb

- Gewicht/m: 44,7 kg
Weight/meter
- Wx: 259 cm³
- Wy: 53 cm³
- ey: 2,32 cm
- Ix: 3117 cm⁴
- Iy: 240 cm⁴

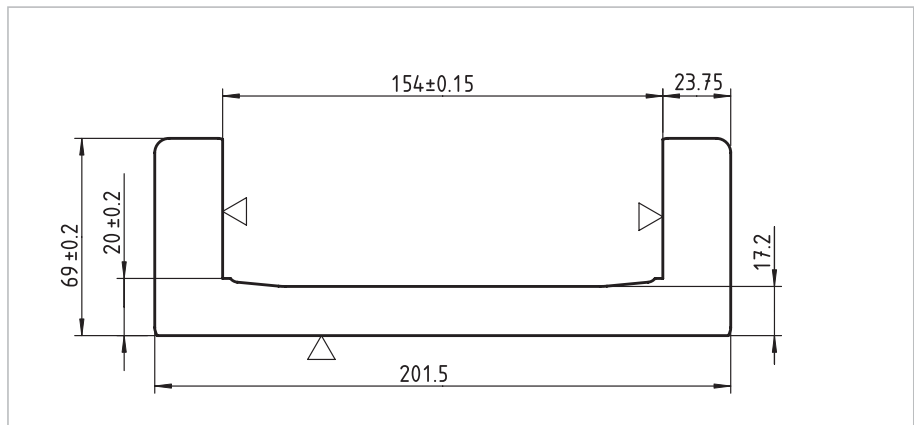

NEU
NEW

PR 8 Nb

- Gewicht/m: 70,59 kg
Weight/meter
- Wx: 635 cm³
- Wy: 111 cm³
- ey: 3,10 cm
- Ix: 8000 cm⁴
- Iy: 623 cm⁴

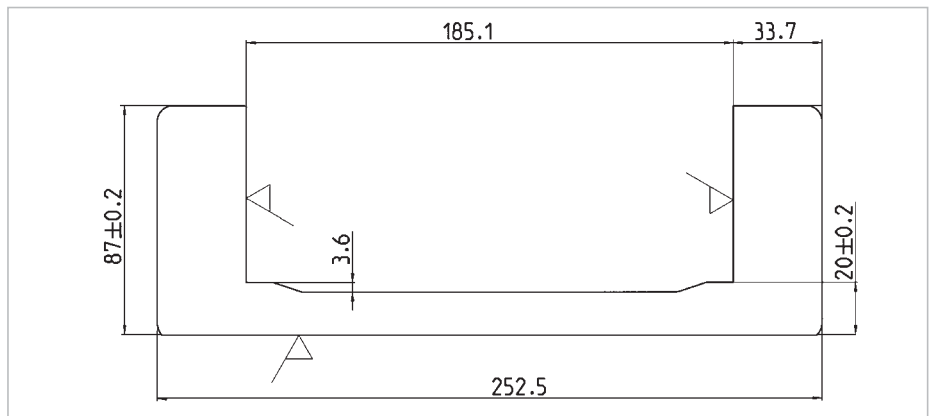



Kombirollen | Combined Bearings

**U-Profil gebohrt
Typ PG - Standard U-Profil**

Vorteile:

- Einbaufertige Profile mit standardisierten Befestigungsbohrungen.
- Alle Profile feingerichtet $\pm 0,3$ mm/lfm.

Max. Länge 12 m. Sonderlängen auf Anfrage.

CAD Download in 2D/3D unter www.winkel.de

**U-profiles drilled
type PG - standard U-profiles**

Advantages:

- Ready to mount profiles with standardized thread holes.
- All profiles fine straightened $\pm 0,3$ mm/m.

Max. length 12 m. Special lengths on request.

CAD download in 2D/3D at www.winkel.de

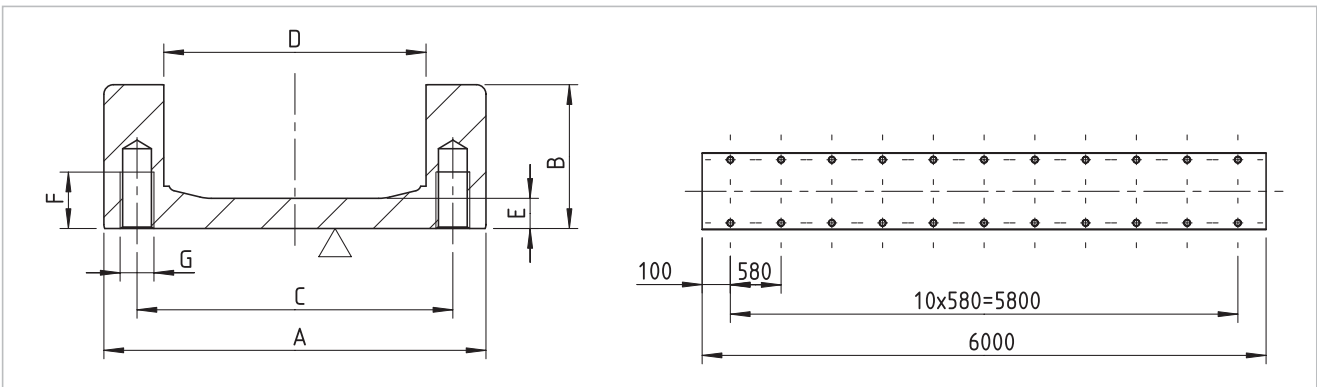

Bestellbeispiel | Order example

PG-2Nb [Profil] 6000 [Lieferbare Längen = Anzahl der Teilung (580 mm) + 200 mm]
 PG-2Nb [Profile] 6000 [Available lengths = amount of pitches (580 mm) + 200 mm]

Profil Profile	A	B	C	D	E	F	G
PG 0 Nb	86,5	35	75,8	62,5 + 1,00	6,0	15	M 8
PG 1 Nb	103,2	39	89,0	70,8 ± 0,50	6,7	18	M 10
PG 2 Nb	121,3	39	101,7	78,7 ± 0,50	8,8	20	M 12
PG 3 Nb	135,4	51	114,2	89,4 ± 0,75	10,7	20	M 12
PG 4 Nb	157,2	59	134,6	108,4 ± 0,80	11,8	20	M 12
PG 5 Nb	175,0	64	151,5	123,8 ± 0,75	14,0	30	M 16
PG 6 Nb	201,5	69	177,8	150,1 ± 0,50	17,2	30	M 16
PG 8 Nb	252,5	87	217,0	181,1 ± 0,70	16,4	40	M 20



PR U-Profile gebohrt Typ PG - PR-Profile

Vorteile:

- Einbaufertige Profile mit standardisierten Befestigungsbohrungen.
- Alle Profile feingerichtet $\pm 0,3$ mm/lfm.
- Geringe Lagerluft zwischen Laufrolle und Profil.

Max. Länge 12 m. Sonderlängen auf Anfrage.

PR U-profiles drilled type PG - PR-profiles

Advantages:

- Ready to mount profiles with standardized thread holes.
- All profiles fine straightened $\pm 0,3$ mm/m.
- Min. clearance between bearing and profile.

Max. length 12 m. Special lengths on request.

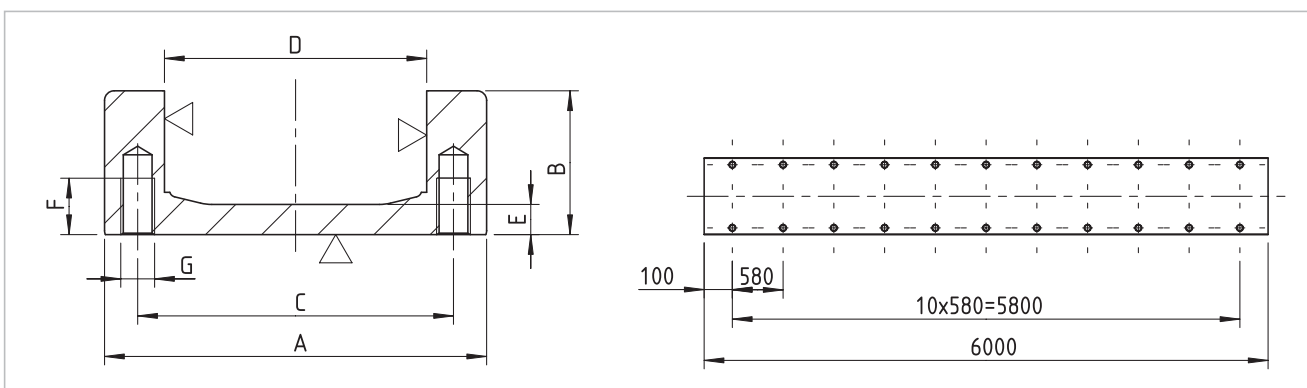

Bestellbeispiel | Order example

PG-PR 0 Nb [Profil] 6000 [Lieferbare Längen = Anzahl der Teilung (580 mm) + 200 mm]
 PG-PR 0 Nb [Profile] 6000 [Available lengths = amount of pitches (580 mm) + 200 mm]

Profil Profile	A	B	C	D	E	F	G
PG-PR 0 Nb	86,5	35	75,8	65	6,0	15	M 8
PG-PR 1 Nb	103,2	39	89,0	74	6,7	18	M 10
PG-PR 2 Nb	121,3	39	101,7	82	8,8	20	M 12
PG-PR 3 Nb	135,4	51	114,2	93	10,7	20	M 12
PG-PR 4 Nb	157,2	59	134,6	112	11,8	20	M 12
PG-PR 5 Nb	175,0	64	151,5	128	14,0	30	M 16
PG-PR 6 Nb	201,5	69	177,8	154	17,2	30	M 16
PG-PR 8 Nb	252,5	87	217,0	185,1	16,4	40	M 20



Doppel T-Profile

- Alle Profile aus hochwertigem Stahl in S355 J2G3 (St 52.3) gefertigt. $L_{\max} = 12 \text{ m}$.
- Passend zu unserem Kombirollensystem liefern wir alle Profiltypen in Fixlängen sofort ab Lager.
- Auf Wunsch sind alle Profile in feingerichteter und sandgestrahlter Ausführung erhältlich.
- Komplette Profilbearbeitung nach Kundenzeichnungen auf Anfrage.

CAD Download in 2D/3D unter www.winkel.de

I-profiles

- All profiles are made from high-quality steel UNI FE 510.C. $L_{\max} = 12 \text{ m}$.
- To our Combined Bearing system we deliver all profiles in fixed lengths, immediately from stock.
- All profiles are available in fine straightened style and sandblasted on request.
- Machined profiles according to customer drawings on request.

CAD download in 2D/3D at www.winkel.de



Hinweis: Doppel-T- Profile sind im Standard nicht sandgestrahlt.
Feingerichtete Profile weisen eine Geradheit von $\pm 0,3 \text{ mm/lfm}$. auf. Standard $\pm 1,0 \text{ mm/lfm}$.



Typ | Type 3018

- Gewicht/m: 19,4 kg
Weight/meter
- Wx: 70,06 cm³
- Wy: 17,62 cm³
- Ix: 343,29 cm⁴
- Iy: 57,14 cm⁴

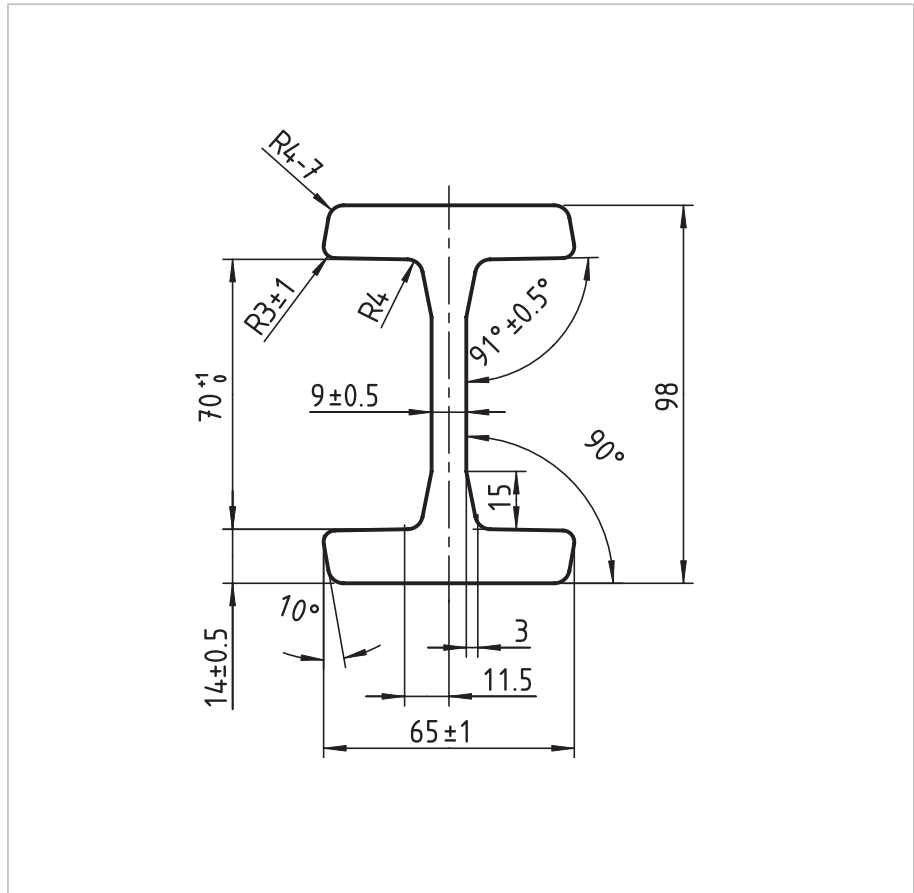

Typ | Type 3019

- Gewicht/m: 25,3 kg
Weight/meter
- Wx: 104,9 cm³
- Wy: 23,2 cm³
- Ix: 597,5 cm⁴
- Iy: 76,8 cm⁴

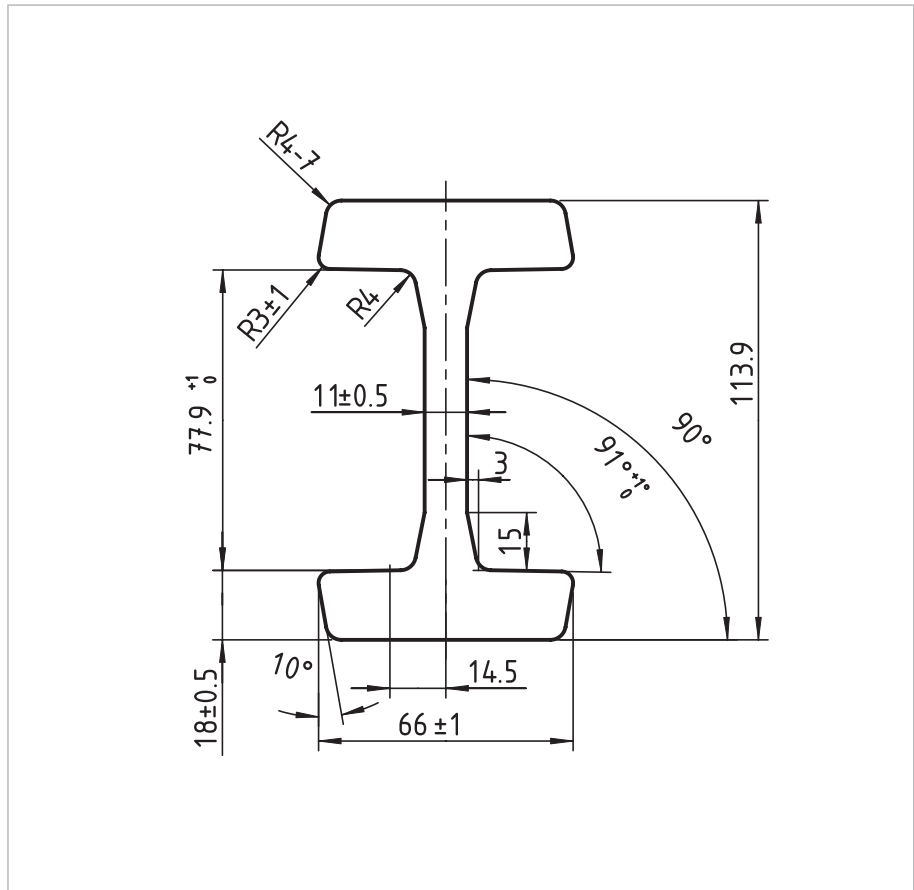

Notice: I-profiles are in standard version not sandblasted.
The straightness for fine straightened profiles is ± 0,3 mm per meter. Standard ± 1,0 per meter



Kombirollen | Combined bearings

Typ | Type 3020

- Gewicht/m: 34,0 kg
Weight/meter
- Wx: 159,73 cm³
- Wy: 40 cm³
- Ix: 1035,09 cm⁴
- Iy: 161 cm⁴

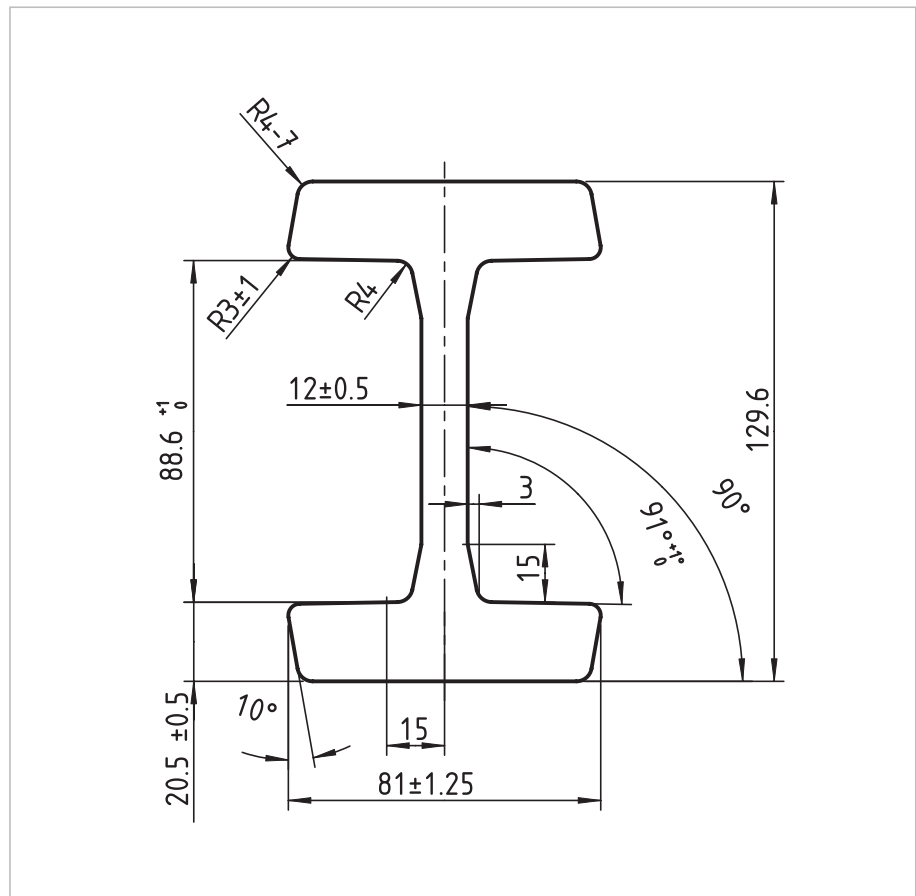

Typ | Type 2912

- Gewicht/m: 31,17 kg
Weight/meter
- Wx: 156,60 cm³
- Wy: 30,5 cm³
- Ix: 1097,89 cm⁴
- Iy: 106,8 cm⁴

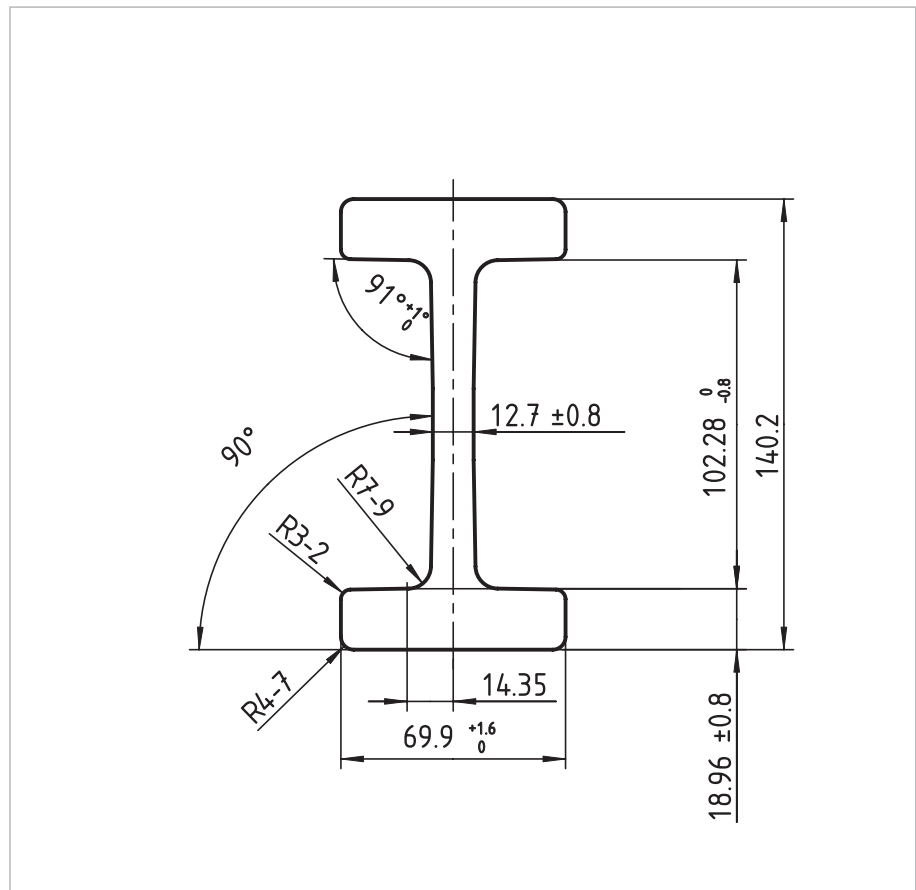

Hinweis: Doppel-T- Profile sind im Standard nicht sandgestrahlt.
Feingerichtete Profile weisen eine Geradheit von $\pm 0,3$ mm/lfm. auf. Standard $\pm 1,0$ mm/lfm.



Typ | Type 3100

- Gewicht/m: 40,8 kg
Weight/meter
- Wx: 219,20 cm³
- Wy: 44,5 cm³
- Ix: 1670,04 cm⁴
- Iy: 184,5 cm⁴

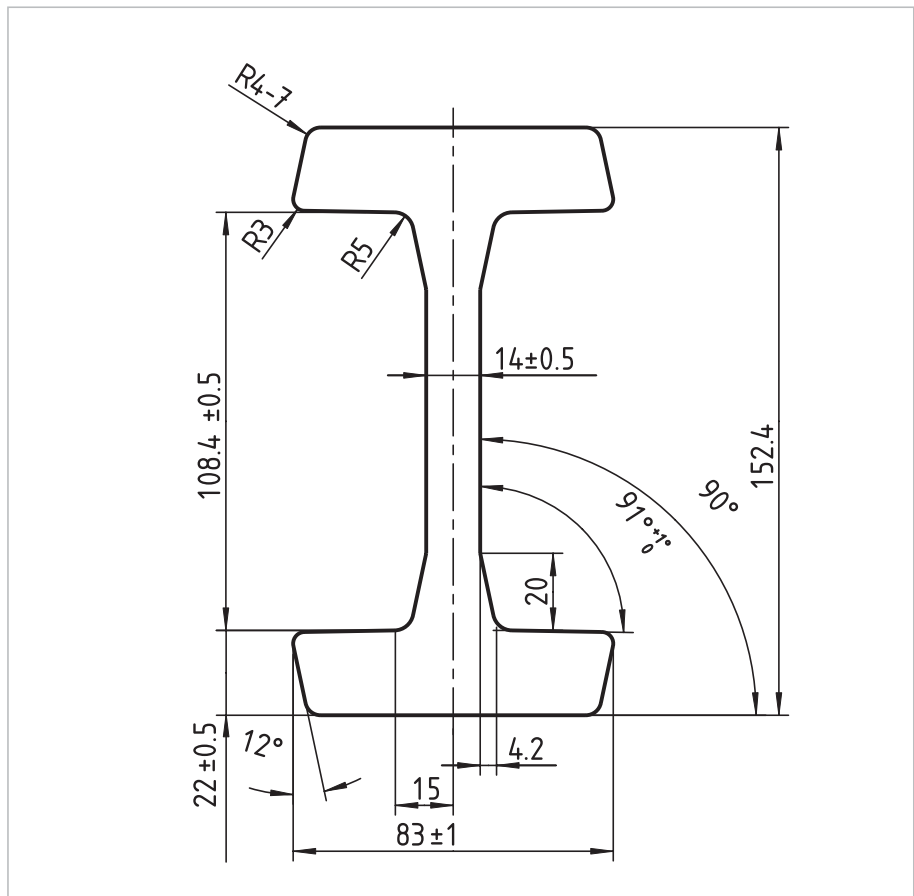

Typ | Type 3353

- Gewicht/m: 51,4 kg
Weight/meter
- Wx: 323,15 cm³
- Wy: 64,70 cm³
- Ix: 2827,58 cm⁴
- Iy: 293,5 cm⁴

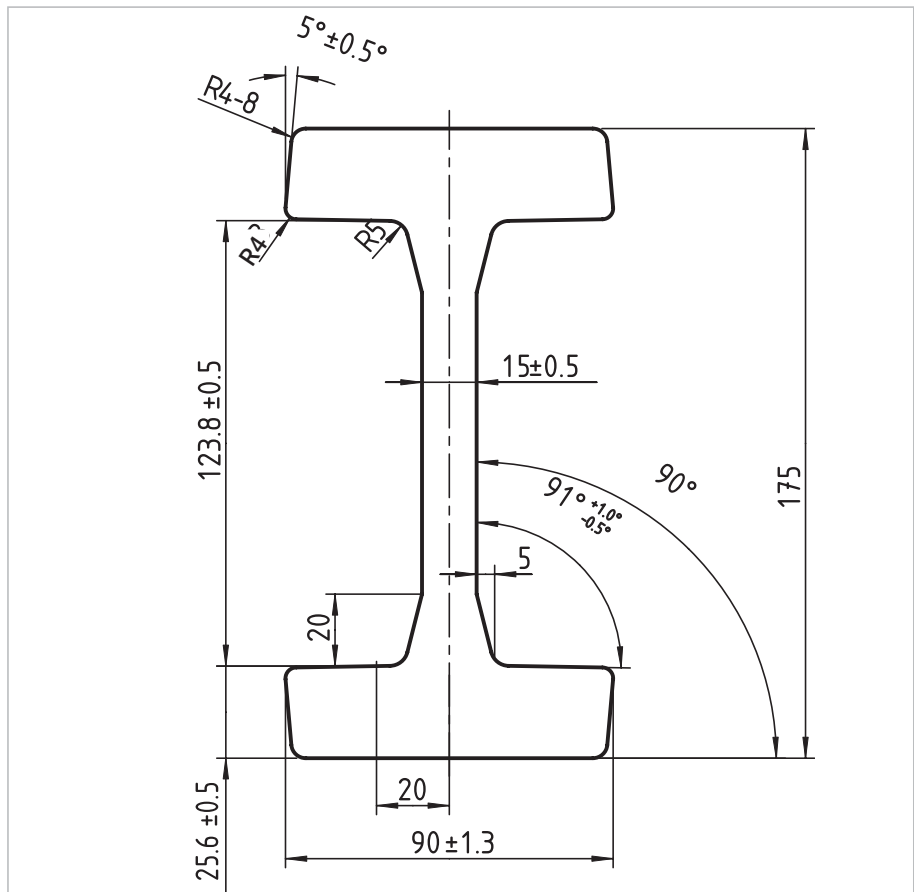

Notice: I-profiles are in standard version not sandblasted.

The straightness for fine straightened profiles is ± 0,3 mm per meter. Standard ± 1,0 per meter



Jumbo-Profile

- Alle Profile sind aus hochwertigem Stahl in S355 J2G3 (St 52.3) gefertigt.
- Passend zu unserem Kombirollensystem werden alle Profile in Fixlänge auftragsbezogen produziert.
- Auf Wunsch ist eine einseitige Laufbahnbearbeitung möglich.
- Maximale Produktionslänge 12 m.

U-Profile und Sonderausführungen auf Anfrage.

CAD Download in 2D/3D unter www.winkel.de

Jumbo-profiles

- All profiles are made from high-quality steel UNI FE 510.C.
- To our Combined Bearing system, we produce all profiles in fixed lengths, according to customers order.
- Low cost version with milled profile only on one side on request.
- Maximum production length 12 m.

U-profiles and special designs on request.

CAD download in 2D/3D at www.winkel.de





Standard 10

- Gewicht/m: 71 kg
Weight/meter
- Tragkraft: ≈10 t
Load capacity
- Wx: 593 cm³
- Wy: 100 cm³
- Ix: 6825 cm⁴
- Iy: 475 cm⁴

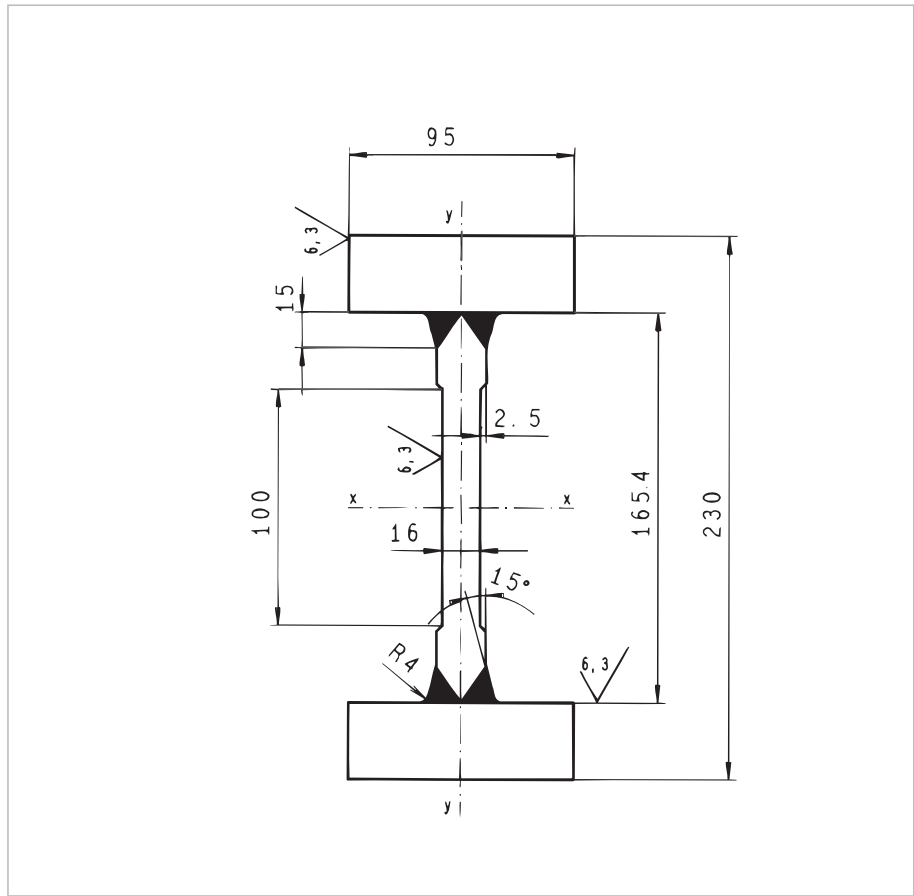

Standard 16

- Gewicht/m: 100 kg
Weight/meter
- Tragkraft: ≈16 t
Load capacity
- Wx: 940 cm³
- Wy: 185 cm³
- Ix: 11983 cm⁴
- Iy: 1203 cm⁴

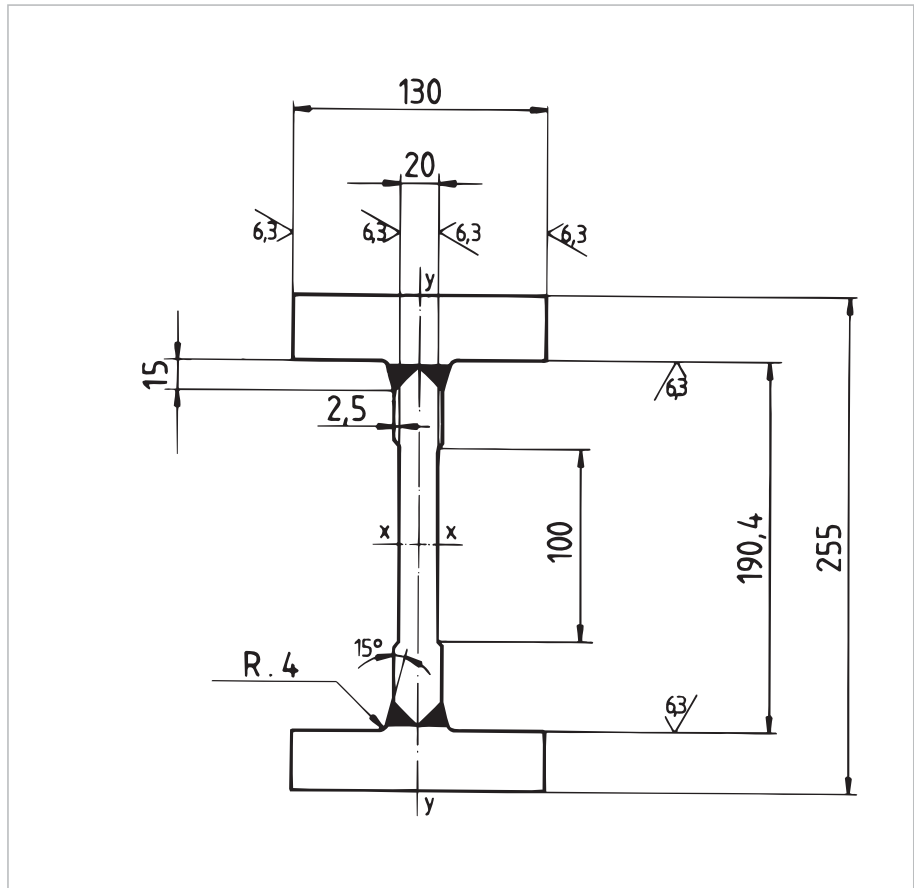



Kombirollen | Combined bearings

Standard 18

- Gewicht/m: 128 kg
Weight/meter
- Tragkraft: ≈18 t
Load capacity
- Wx: 1426 cm³
- Wy: 283 cm³
- Ix: 21035 cm⁴
- Iy: 2123 cm⁴

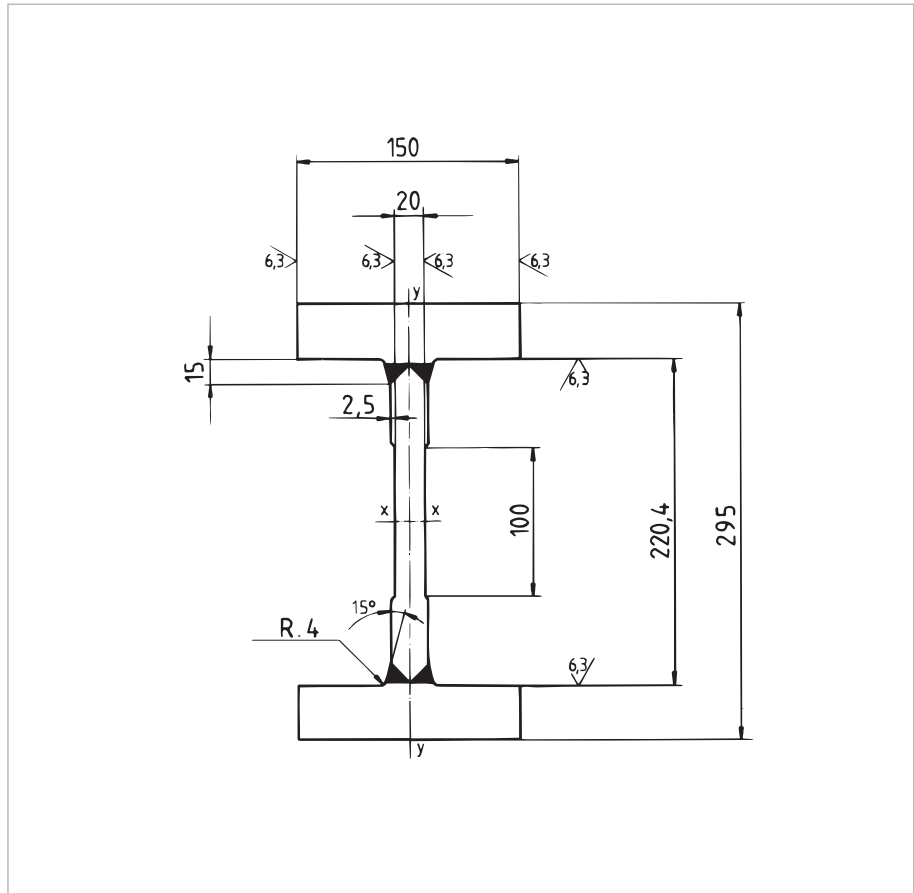

Standard 28

- Gewicht/m: 175 kg
Weight/meter
- Tragkraft: ≈28 t
Load capacity
- Wx: 2196 cm³
- Wy: 410 cm³
- Ix: 37883 cm⁴
- Iy: 3279 cm⁴

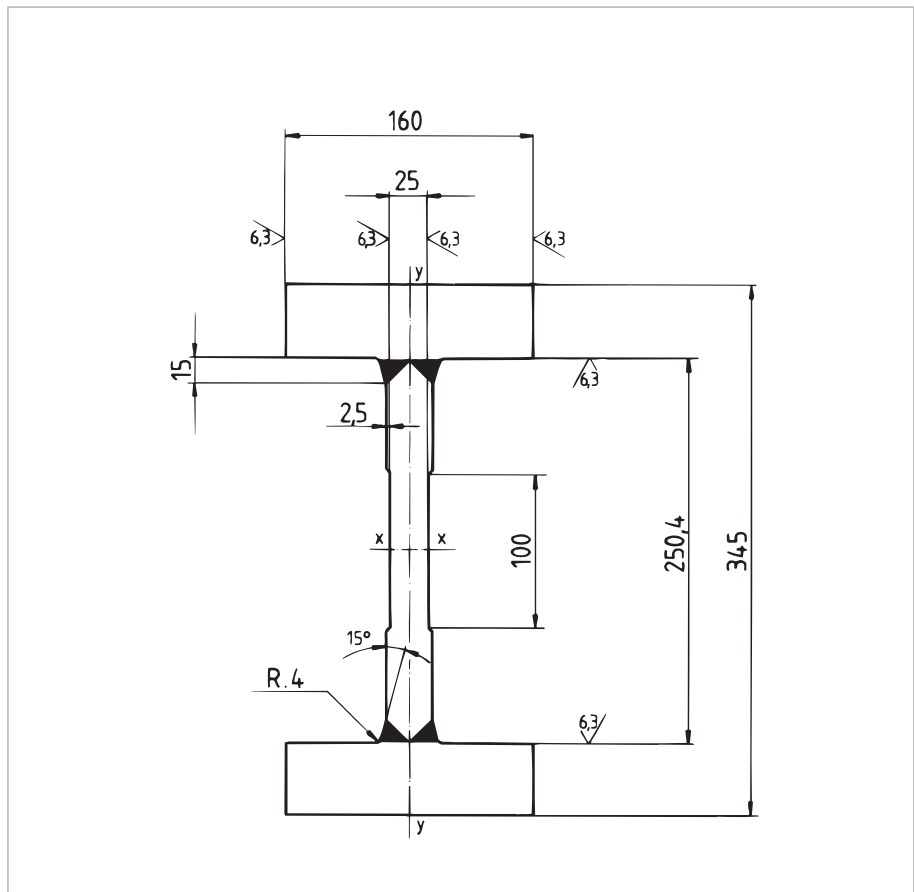



Standard 36

■ Gewicht/m: 215 kg
Weight/meter

■ Tragkraft: ≈36 t
Load capacity

■ Wx: 2945 cm³
 ■ Wy: 578 cm³
 ■ Ix: 55210 cm⁴
 ■ Iy: 5498 cm⁴

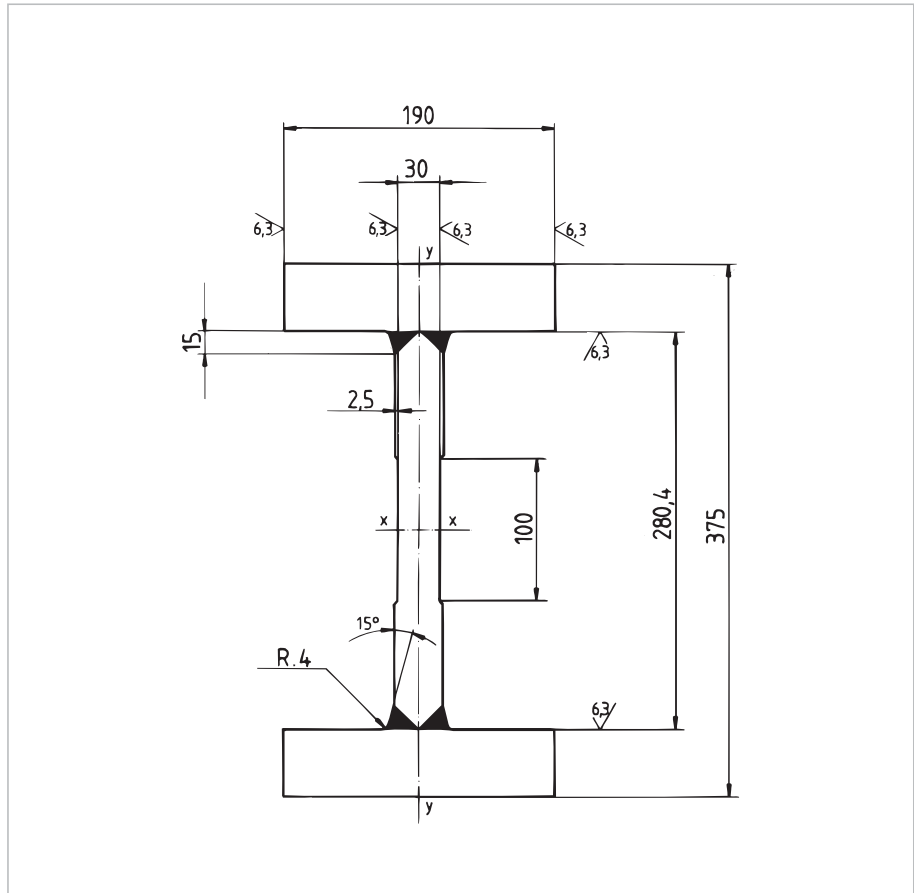

Standard 42

■ Gewicht/m: 245 kg
Weight/meter

■ Tragkraft: ≈42 t
Load capacity

■ Wx: 3505 cm³
 ■ Wy: 700 cm³
 ■ Ix: 69230 cm⁴
 ■ Iy: 6642 cm⁴

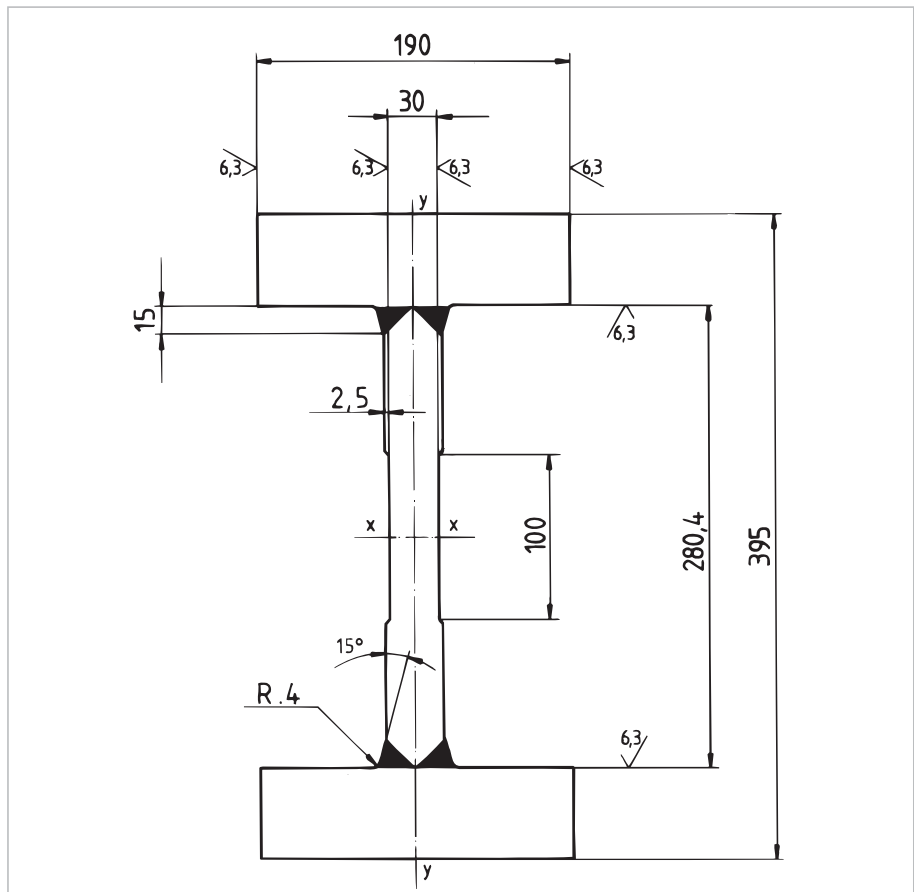



Anschaubplatten rechteckig für Kombirollen und Radiallager

WINKEL Kombirollen mit Anschraubplatten sind fertige Systemelemente für schraubbare Verbindungen zwischen Konstruktion und Führungsprofil.

- alle Anschraubplatten mit eingeschweißter Kombirolle
- axiale Justierung mit Distanzscheiben Typ DS
- alle Anschraubplatten in brüniertem Ausführung
- Material: S235 JR (St 37.2)

Sonderausführungen auf Anfrage.

CAD Download in 2D/3D unter www.winkel.de

Flange plates rectangular for Combined Bearings and Radial Bearings

WINKEL flange plates in combination with Combined Bearings are suitable for screw joints between constructions and guide profiles.

- all flange plates incl. welded in Combined Bearings
- axial adjusting with washers type DS
- all flange plates in corrosion protected version
- material: UNI FE 360 B

Special designs on request.

CAD download in 2D/3D at www.winkel.de

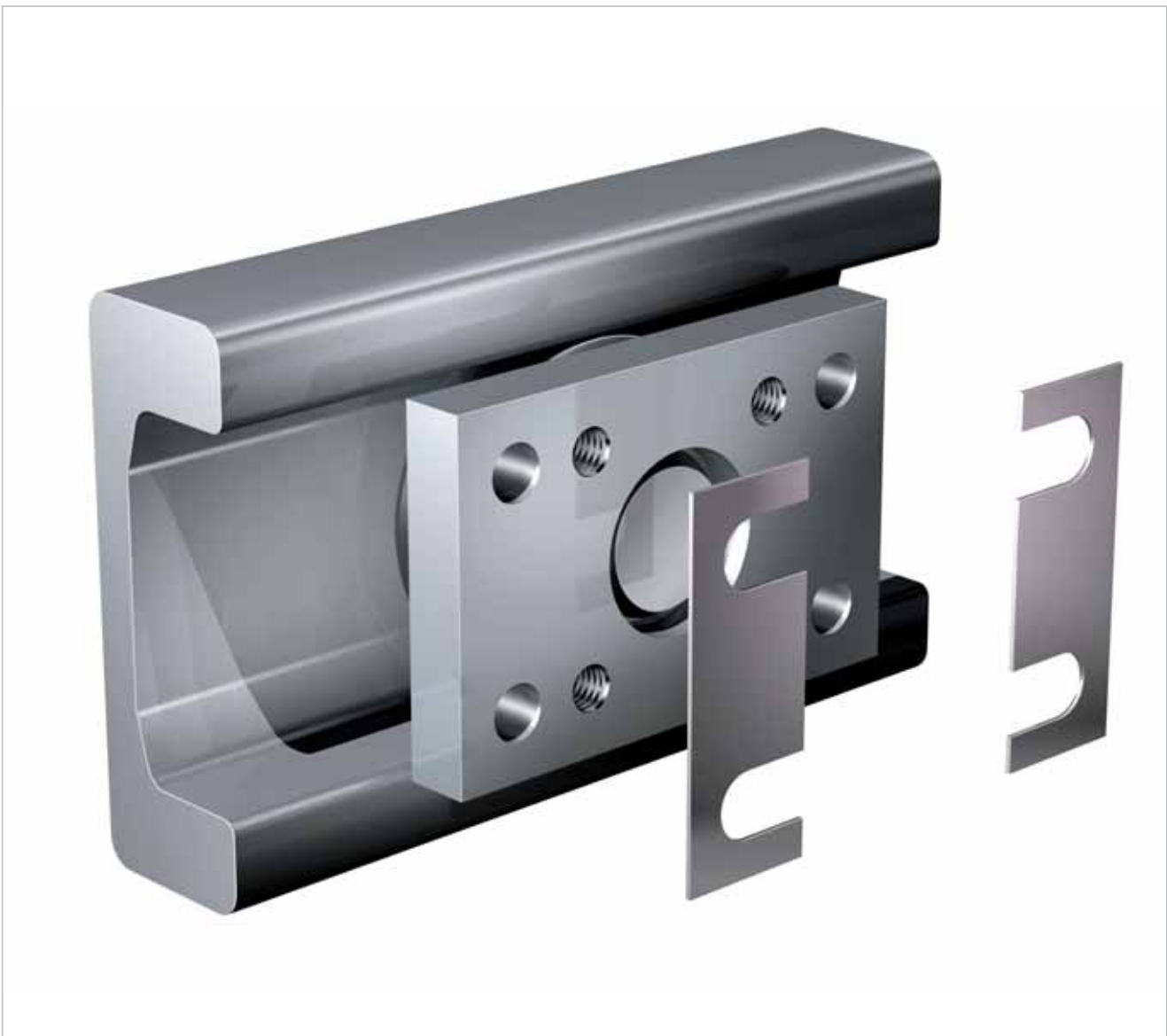



AP A

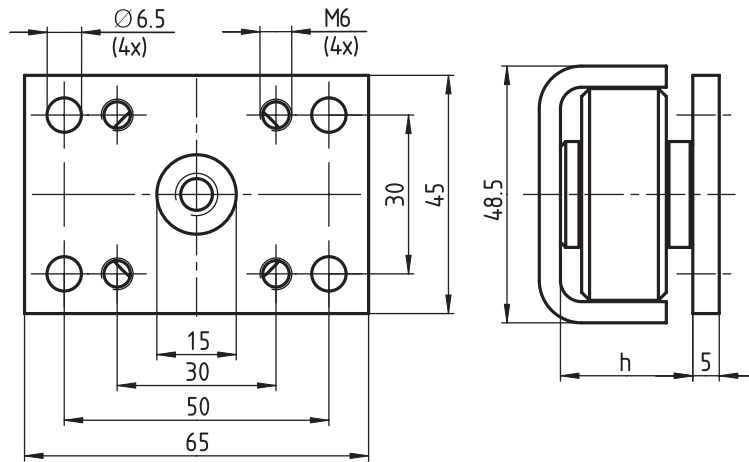

Typ Type	Rolle Bearing	Profil Profile	h h	Gewicht Weight	Distanzscheiben Washer
AP A	4.052 P	Standard A	25,0	0,10 kg	DS-A-0,5 DS-A-1,0

AP S

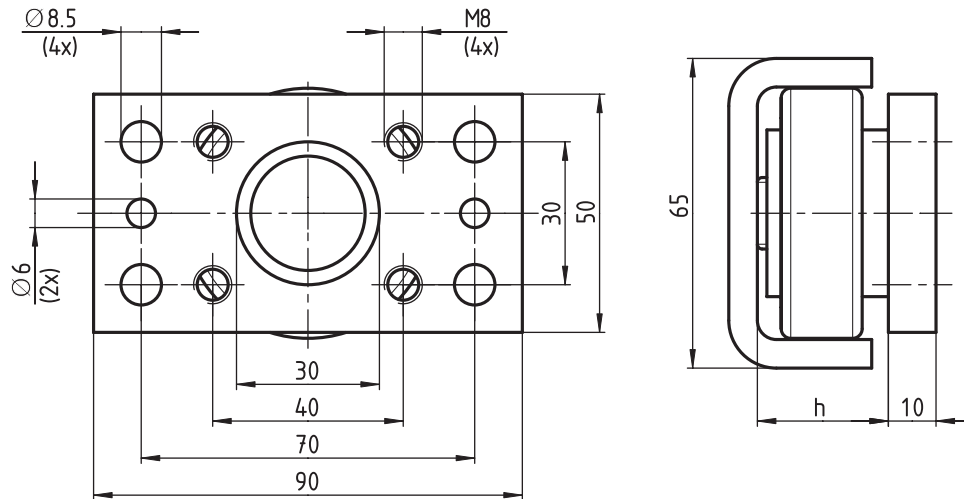

Typ Type	Rolle Bearing	Profil Profile	h h	Gewicht Weight	Distanzscheiben Washer
AP S	4.053	Standard S	27,0	0,25 kg	DS-S-0,5 DS-S-1,0



Kombirollen | Combined Bearings

AP 0

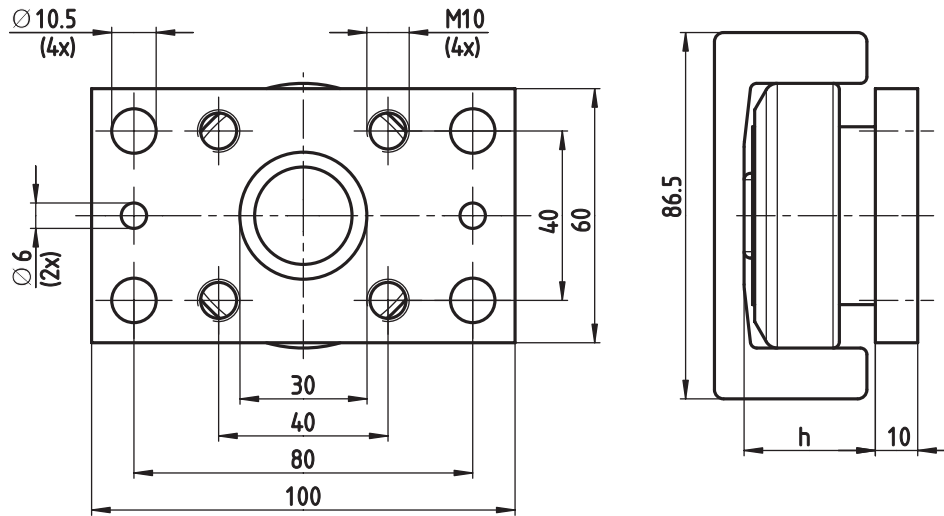

Typ Type	Rolle Bearing	Profil Profile	h h	Gewicht Weight	Distanzscheiben Washer
AP 0	2.054	Standard 0 Nb	30,5	0,35 kg	DS-0-0,5 DS-0-1,0
	4.054	Standard 0 Nb	30,5		
	4.454	Standard 0 Nb	30,5 - 32,0		
	4.072(P)	Standard 0 Nb	33,0		
	PR 2.054	PR 0 Nb	29,5		
	PR 4.054	PR 0 Nb	30,5		
	PR 4.454	PR 0 Nb	30,5 - 32,0		

AP 1

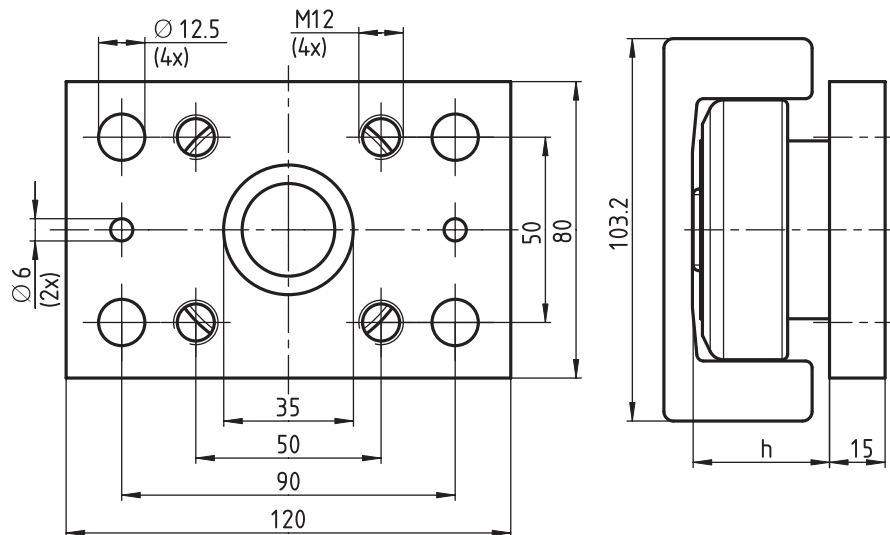

Typ Type	Rolle Bearing	Profil Profile	h h	Gewicht Weight	Distanzscheiben Washer
AP 1	2.055	Standard 1 Nb	36,0	0,90 kg	DS-1-0,5 DS-1-1,0
	4.055	Standard 1 Nb	36,0		
	4.455	Standard 1 Nb	36,0 - 37,5		
	4.073(P)	Standard 1 Nb	40,0		
	PR 2.055	PR 1 Nb	36,0		
	PR 4.055	PR 1 Nb	36,0		
	PR 4.455	PR 1 Nb	36,0 - 37,5		

Kombirollen | Combined Bearings



AP 2

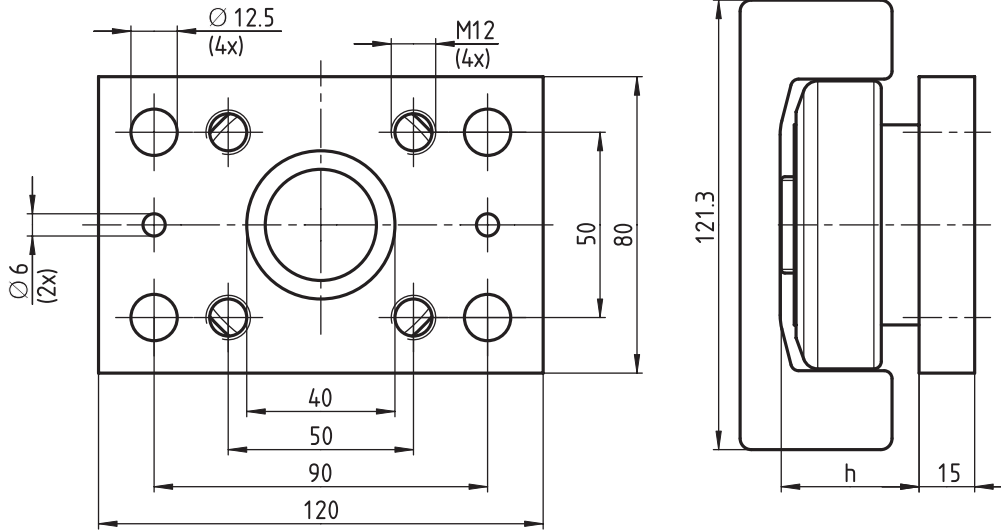

Typ Type	Rolle Bearing	Profil Profile	h h	Gewicht Weight	Distanzscheiben Washer
AP 2	2.056	Standard 2 Nb	36,5	0,85 kg	DS-2-0,5 DS-2-1,0
	4.056	Standard 2 Nb	36,5		
	4.456	Standard 2 Nb	37,0 - 38,5		
	4.074(P)	Standard 2 Nb	39,5		
	PR 2.056	PR 2 Nb	36,5		
	PR 4.056	PR 2 Nb	36,5		
	PR 4.456	PR 2 Nb	37,0 - 38,5		

AP 3.1

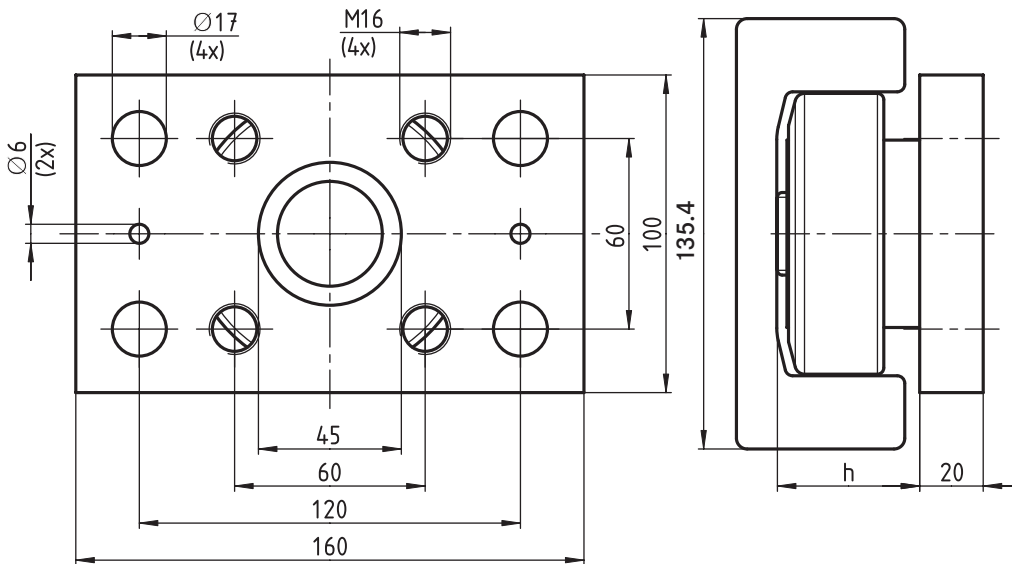

Typ Type	Rolle Bearing	Profil Profile	h h	Gewicht Weight	Distanzscheiben Washer
AP 3.1	2.058	Standard 3 Nb	44,0	2,35 kg	DS-3.1-0,5 DS-3.1-1,0
	4.058	Standard 3 Nb	44,0		
	4.458	Standard 3 Nb	44,0 - 45,5		
	4.076(P)	Standard 3 Nb	48,0		
	PR 2.058	PR 3 Nb	44,0		
	PR 4.058	PR 3 Nb	44,0		
	PR 4.458	PR 3 Nb	44,0 - 45,5		



Kombirollen | Combined Bearings

AP 4

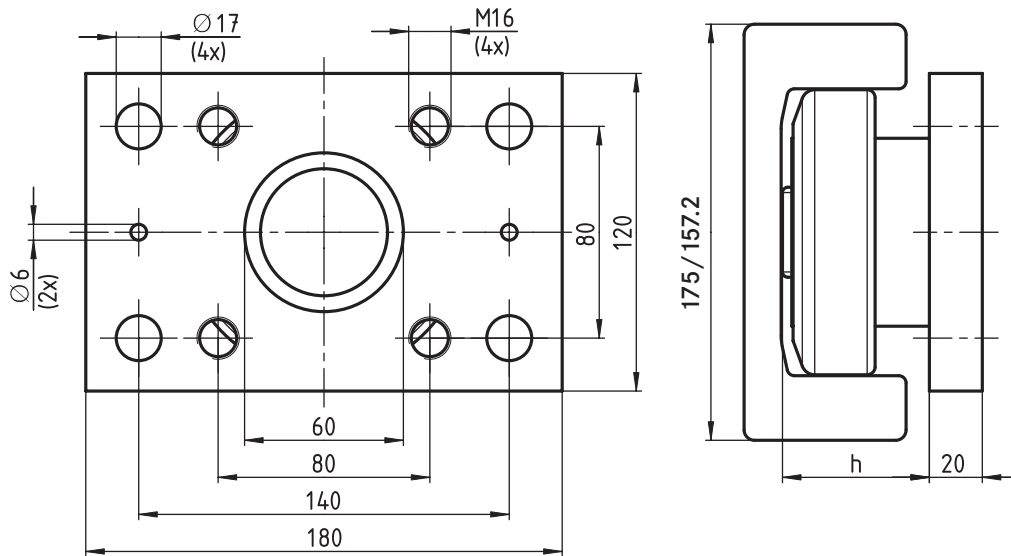

Typ Type	Rolle Bearing	Profil Profile	h h	Gewicht Weight	Distanzscheiben Washer
AP 4	2.061	Standard 4 Nb	55,0	2,65 kg	DS-4-0,5 DS-4-1,0
	4.061	Standard 4 Nb	55,0		
	4.461	Standard 4 Nb	55,0 - 57,0		
	4.0784(P)	Standard 4 Nb	55,0		
	PR 2.061	PR 4 Nb	55,0		
	PR 4.061	PR 4 Nb	55,0		
	PR 4.461	PR 4 Nb	55,0 - 57,0		
	2.062	Standard 5 Nb	56,0		
	4.062	Standard 5 Nb	56,0		
	4.462	Standard 5 Nb	56,0 - 60,0		
	4.079(P)	Standard 5 Nb	59,5		
	PR 2.062	PR 5 Nb	56,0		
	PR 4.062	PR 5 Nb	56,0		
	PR 4.462	PR 5 Nb	56,0 - 60,0		



AP 6

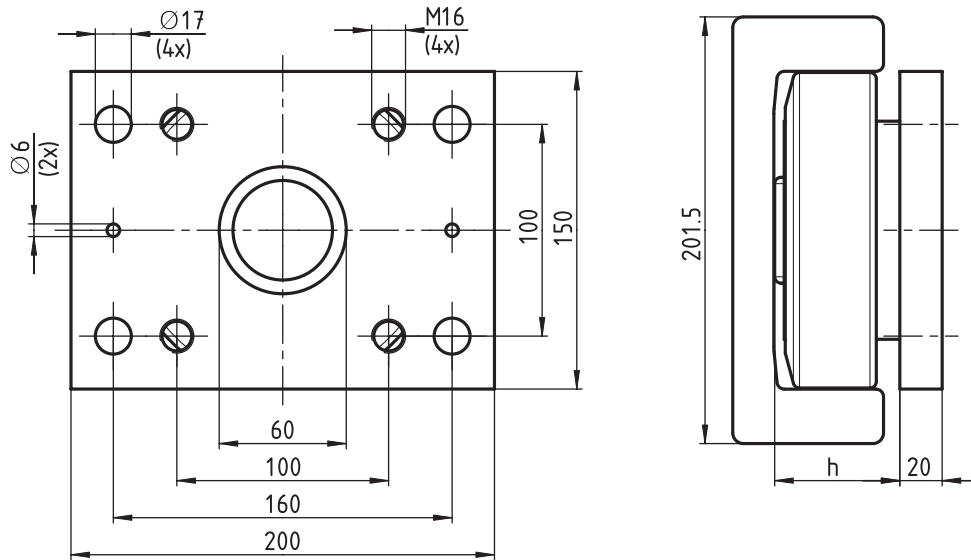

Typ Type	Rolle Bearing	Profil Profile	h h	Gewicht Weight	Distanzscheiben Washer
AP 6	2.063	Standard 6 Nb	58,5	4,0 kg	DS-6-0,5 DS-6-1,0
	4.063	Standard 6 Nb	58,5		
	4.463	Standard 6 Nb	58,5 - 62,5		
	4.080	Standard 6 Nb	69,0		
	4.080 P	Standard 6 Nb	62,0		
	PR 2.063	PR 6 Nb	58,5		
	PR 4.063	PR 6 Nb	58,5		
	PR 4.463	PR 6 Nb	58,5 - 62,5		



Anschaubplatten quadratisch für Kombirollen und Radiallager

WINKEL Kombirollen mit Anschraubplatten sind fertige Systemelemente für schraubbare Verbindungen zwischen Konstruktion und Führungsprofil.

- alle Anschraubplatten mit eingeschweißter Kombirolle
- axiale Justierung mit Distanzscheiben Typ DS
- alle Anschraubplatten in brüniertem Ausführung
- Material: S235 JR (St. 37.2)

Sonderausführungen auf Anfrage.

CAD Download in 2D/3D unter www.winkel.de

Flange plates square for Combined Bearings and Radial Bearings

WINKEL flange plates in combination with Combined Bearings are suitable for screw joints between constructions and guide profiles.

- all flange plates incl. welded in Combined Bearings
- axial adjusting with washers type DS
- all flange plates in corrosion protected version
- material UNI FE 360 B

Special designs on request.

CAD download in 2D/3D at www.winkel.de

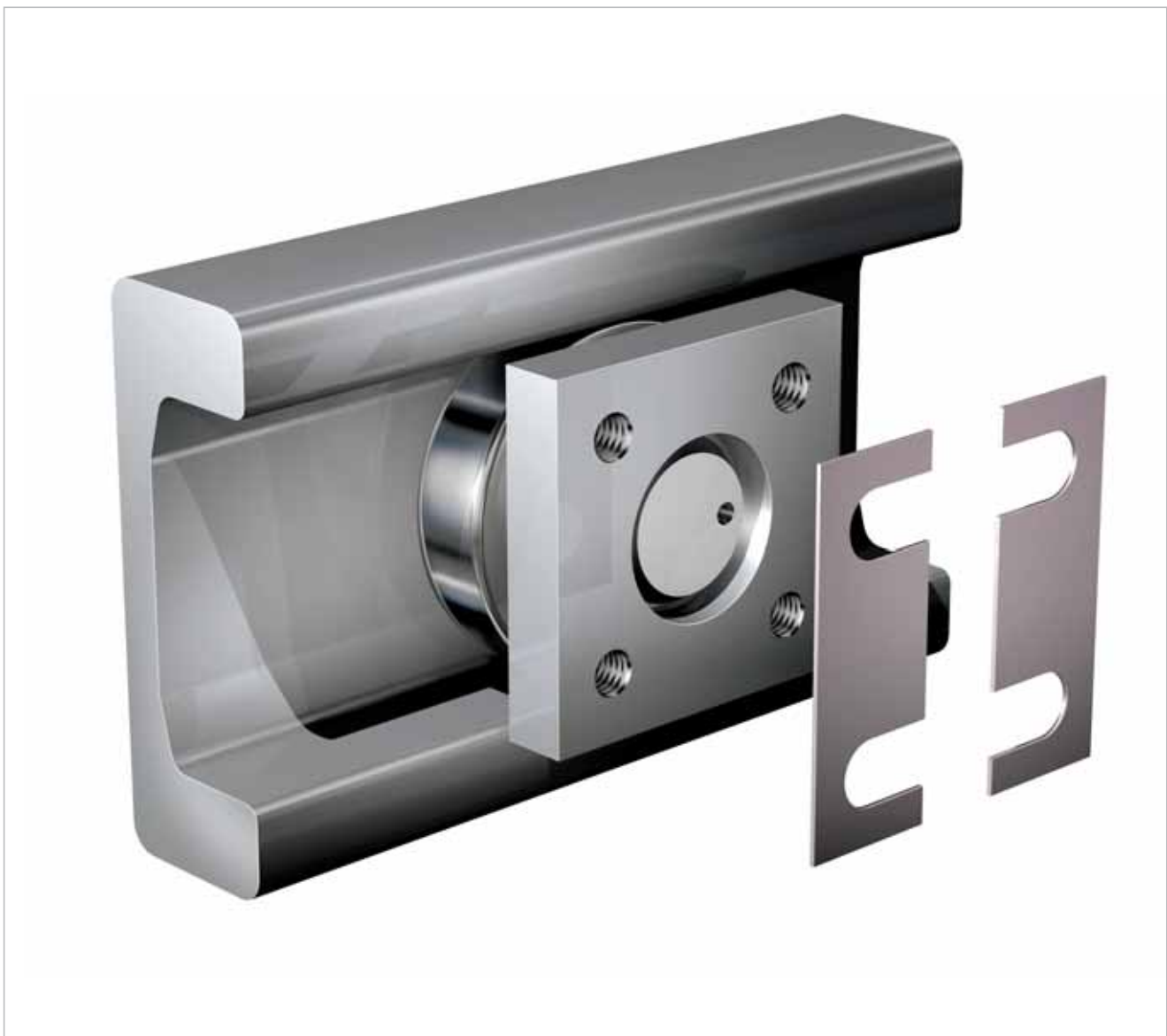

Kombirollen | Combined Bearings



AP A-Q

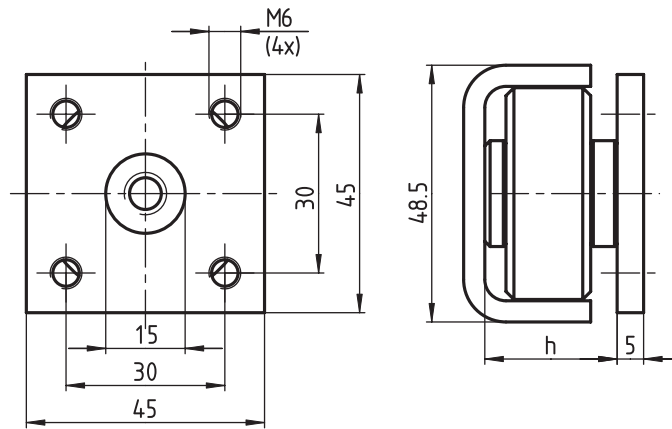

Typ Type	Rolle Bearing	Profil Profile	h h	Gewicht Weight	Distanzscheiben Washer	
AP A-Q	4.052 P	Standard A	25,0	0,1 kg	DS-A-0,5	DS-A-1,0

AP S-Q

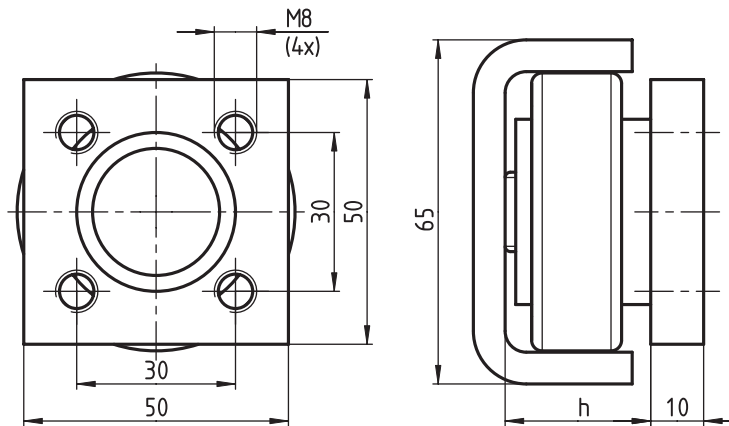

Typ Type	Rolle Bearing	Profil Profile	h h	Gewicht Weight	Distanzscheiben Washer	
AP S-Q	4.053	Standard S	27,0	0,2 kg	DS-S-0,5	DS-S-1,0



Kombirollen | Combined Bearings

AP 0-Q

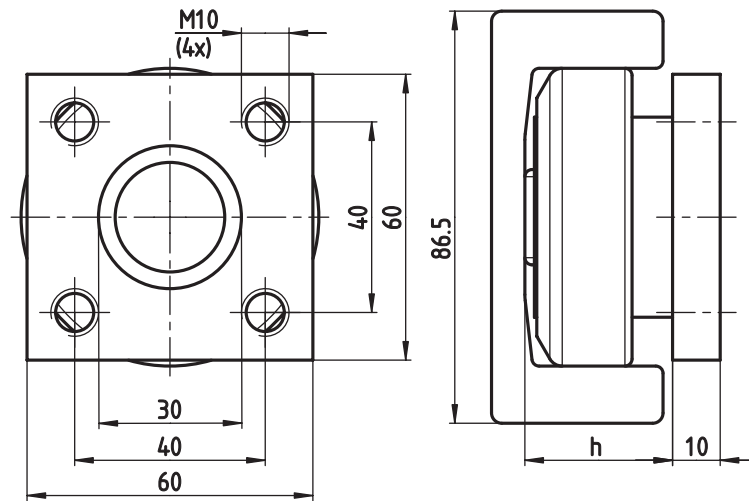

Typ Type	Rolle Bearing	Profil Profile	h h	Gewicht Weight	Distanzscheiben Washer
AP 0-Q	2.054	Standard 0 Nb	30,5	0,28 kg	DS-0-0,5 DS-0-1,0
	4.054	Standard 0 Nb	30,5		
	4.454	Standard 0 Nb	30,5 - 32,0		
	4.072(P)	Standard 0 Nb	33,0		
	PR 2.054	PR 0 Nb	30,5		
	PR 4.054	PR 0 Nb	30,5		
PR 4.454	PR 0 Nb	30,5 - 32,0			

AP 1-Q

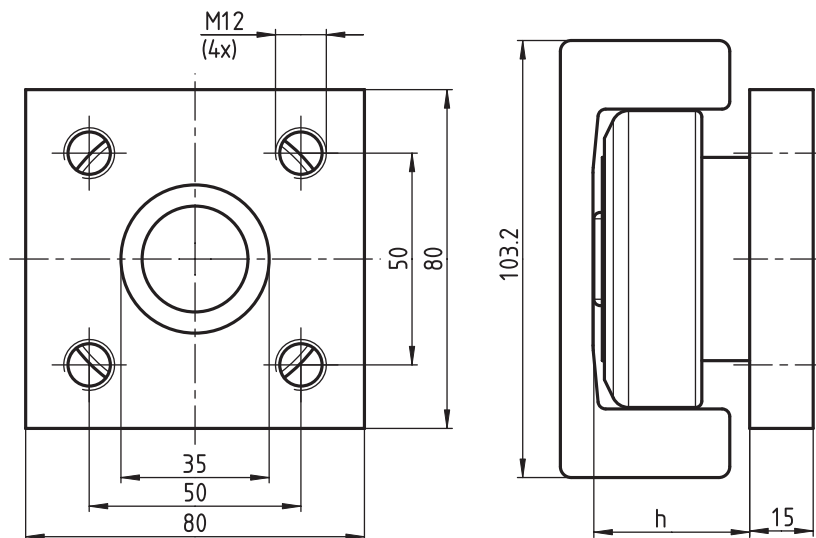

Typ Type	Rolle Bearing	Profil Profile	h h	Gewicht Weight	Distanzscheiben Washer
AP 1-Q	2.055	Standard 1 Nb	36,0	0,75 kg	DS-1-0,5 DS-1-1,0
	4.055	Standard 1 Nb	36,0		
	4.455	Standard 1 Nb	36,0 - 37,5		
	4.073(P)	Standard 1 Nb	40,0		
	PR 2.055	PR 1 Nb	36,0		
	PR 4.055	PR 1 Nb	36,0		
PR 4.455	PR 1 Nb	36,0 - 37,5			



AP 2-Q

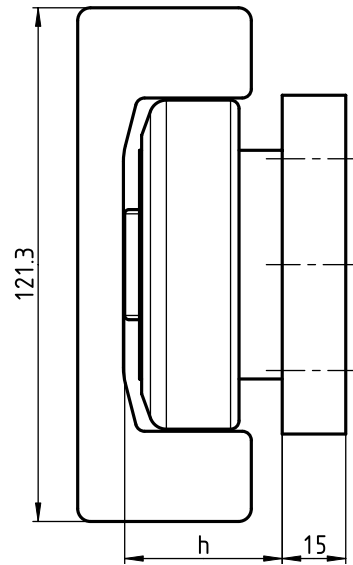
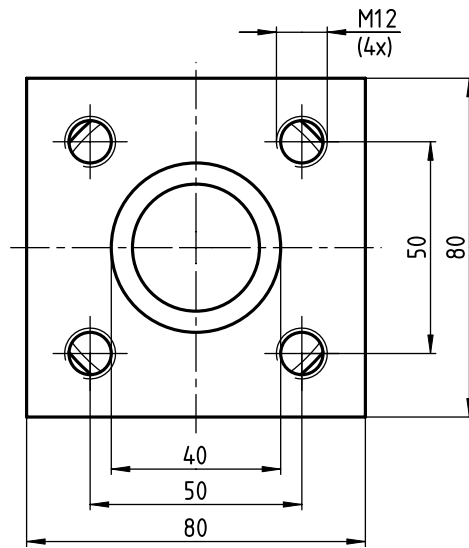

Typ Type	Rolle Bearing	Profil Profile	h h	Gewicht Weight	Distanzscheiben Washer
AP 2-Q	2.056	Standard 2 Nb	36,5	0,75 kg	DS-2-0,5 DS-2-1,0
	4.056	Standard 2 Nb	36,5		
	4.456	Standard 2 Nb	37,0 - 38,5		
	4.074(P)	Standard 2 Nb	39,5		
	PR 2.056	PR 2 Nb	36,5		
	PR 4.056	PR 2 Nb	36,5		
	PR 4.456	PR 2 Nb	37,0 - 38,5		

AP 3-Q

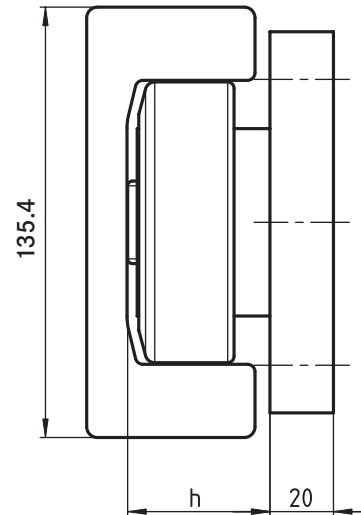
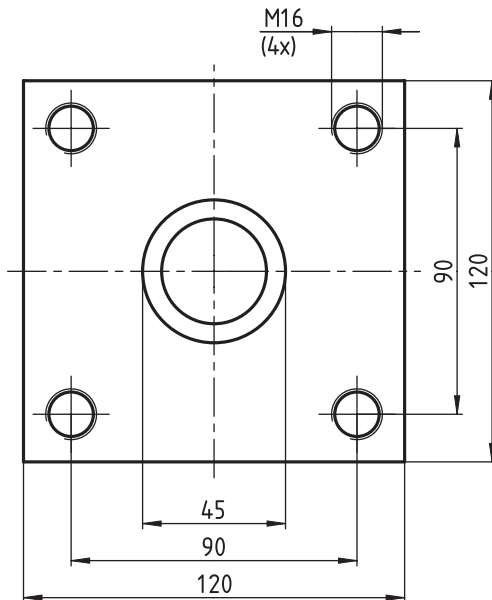

Typ Type	Rolle Bearing	Profil Profile	h h	Gewicht Weight	Distanzscheiben Washer
AP 3-Q	2.058	Standard 3 Nb	44,0	1,85 kg	DS-3-0,5 DS-3-1,0
	4.058	Standard 3 Nb	44,0		
	4.458	Standard 3 Nb	44,0 - 45,5		
	4.076(P)	Standard 3 Nb	48,0		
	PR 2.058	PR 3 Nb	44,0		
	PR 4.058	PR 3 Nb	44,0		
	PR 4.458	PR 3 Nb	44,0 - 45,5		



Kombirollen | Combined Bearings

AP 4-Q

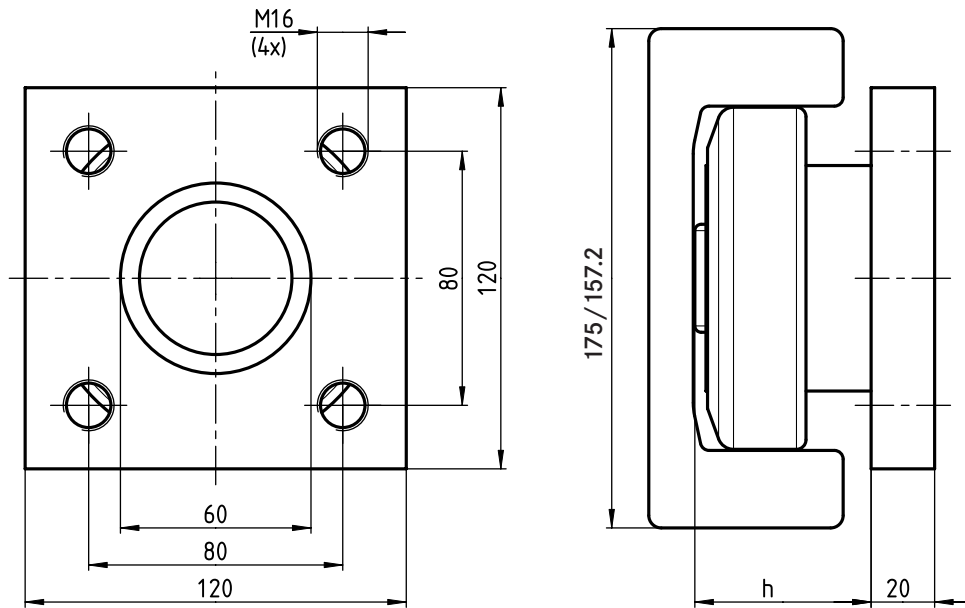

Typ Type	Rolle Bearing	Profil Profile	h h	Gewicht Weight	Distanzscheiben Washer
AP 4-Q	2.061	Standard 4 Nb	55,0	2,2 kg	DS-4-0,5 DS-4-1,0
	4.061	Standard 4 Nb	55,0		
	4.461	Standard 4 Nb	55,0 - 57,0		
	4.0784(P)	Standard 4 Nb	55,0		
	PR 2.061	PR 4 Nb	55,0		
	PR 4.061	PR 4 Nb	55,0		
	PR 4.461	PR 4 Nb	55,0 - 57,0		
	2.062	Standard 5 Nb	56,0		
	4.062	Standard 5 Nb	56,0		
	4.462	Standard 5 Nb	56,0 - 60,0		
	4.079(P)	Standard 5 Nb	59,5		
	PR 2.062	PR 5 Nb	56,0		
	PR 4.062	PR 5 Nb	56,0		
	PR 4.462	PR 5 Nb	56,0 - 60,0		



AP 6-Q

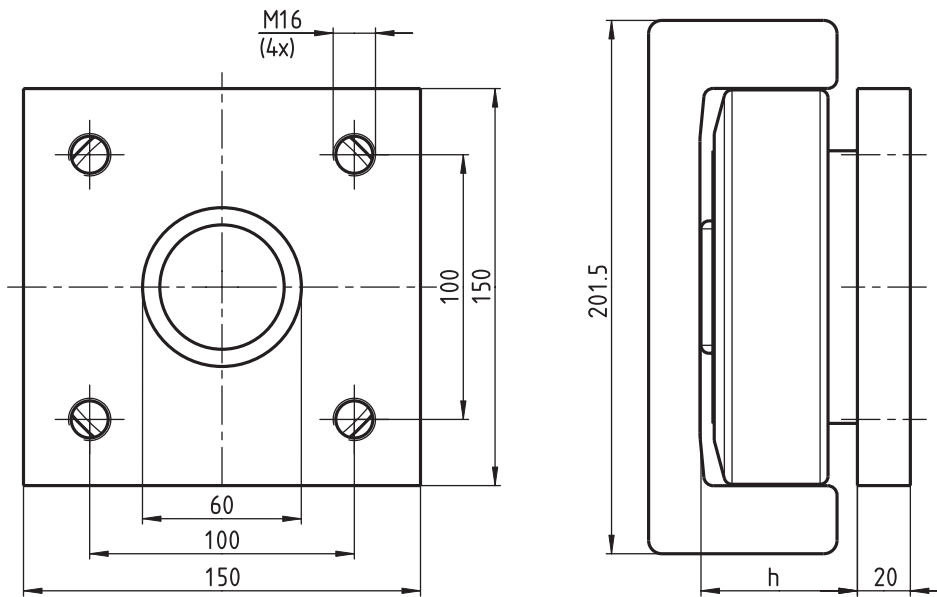

Typ Type	Rolle Bearing	Profil Profile	h h	Gewicht Weight	Distanzscheiben Washer
AP 6-Q	2.063	Standard 6 Nb	58,5	3,4 kg	DS-6-0,5 DS-6-1,0
	4.063	Standard 6 Nb	58,5		
	4.463	Standard 6 Nb	58,5 - 62,5		
	4.080	Standard 6 Nb	69,0		
	4.080 P	Standard 6 Nb	62,0		
	PR 2.063	PR 6 Nb	58,5		
	PR 4.063	PR 6 Nb	58,5		
	PR 4.463	PR 6 Nb	58,5 - 62,5		



Anschaubplatten quadratisch für Jumbo-Kombirollen

WINKEL Kombirollen mit Anschraubplatten sind fertige Systemelemente für schraubbare Verbindungen zwischen Konstruktion und Führungsprofil.

- alle Anschraubplatten mit eingeschweißter Kombirolle
- Axiale Justierung mit Distanzscheiben Typ DS
- alle Anschraubplatten in brüniertem Ausführung
- Material: S235 JR (St. 37.2)

Sonderausführungen auf Anfrage.

CAD Download in 2D/3D unter www.winkel.de

Flange plates square for Jumbo Combined Bearings

WINKEL flange plates in combination with Combined Bearings are suitable for screw joints between constructions and guide profiles.

- all flange plates incl. welded in Combined Bearings
- axial adjusting with washers type DS
- all flange plates in corrosion protected version
- material: UNI FE 360 B

Special designs on request.

CAD download in 2D/3D at www.winkel.de





AP 89-Q

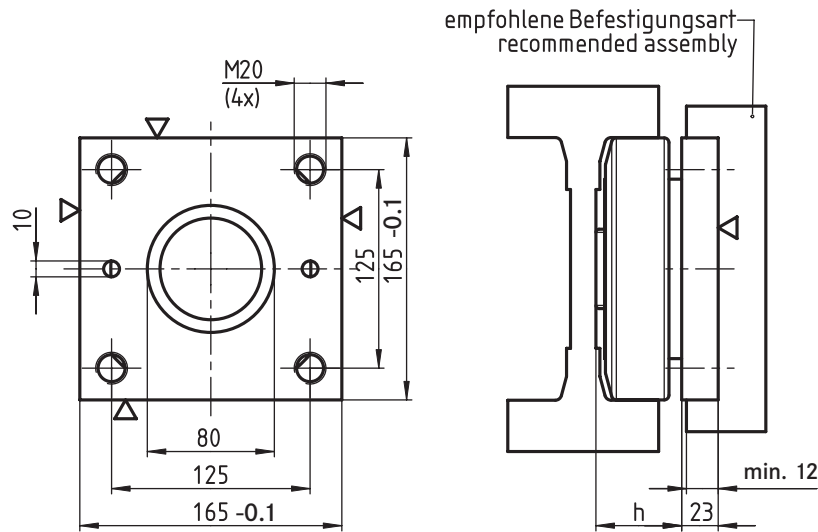

Typ Type	Rolle Bearing	Profil Profile	h h	Gewicht Weight	Distanzscheiben Washer
AP 89-Q	4.089	Standard 10	53-56	4,9	DS-89-0,5 DS-89-1,0

AP 90-Q

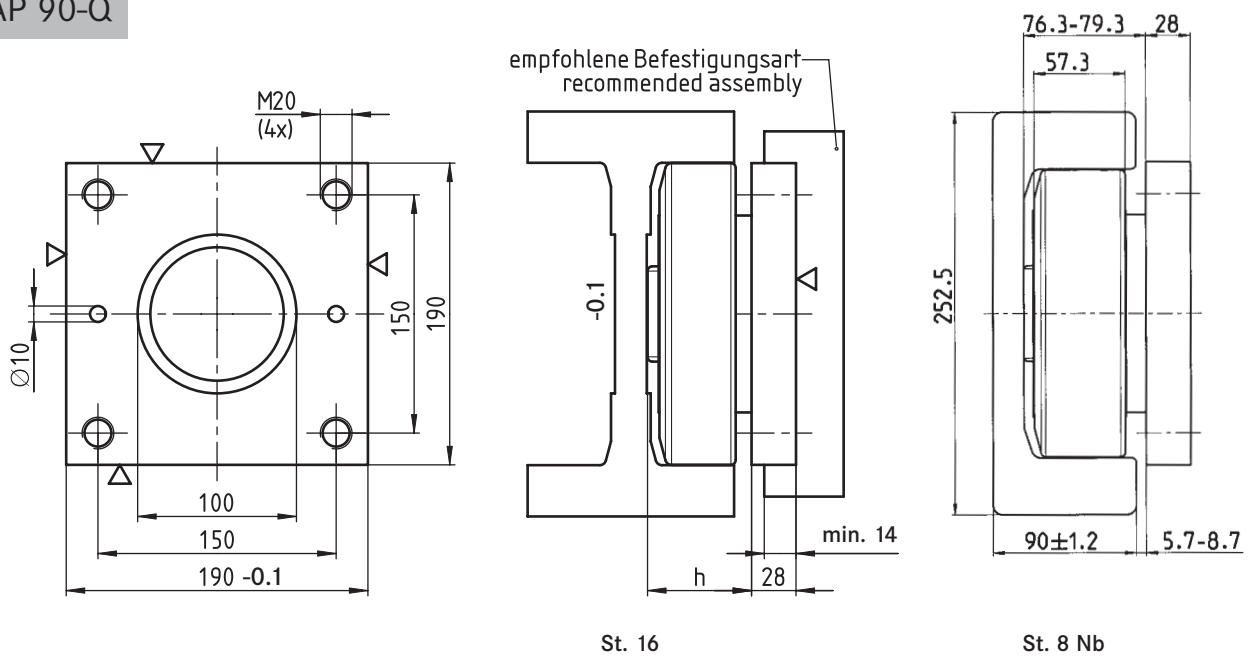

Typ Type	Rolle Bearing	Profil Profile	h h	Gewicht Weight	Distanzscheiben Washer
AP 90-Q	4.085	Standard 8	76,3-79,3	7,9	DS-90-0,5 DS-90-1,0
	4.090	Standard 16	64,5-67,5	7,9	DS-90-0,5 DS-90-1,0



Kombirollen | Combined Bearings

AP 91-Q

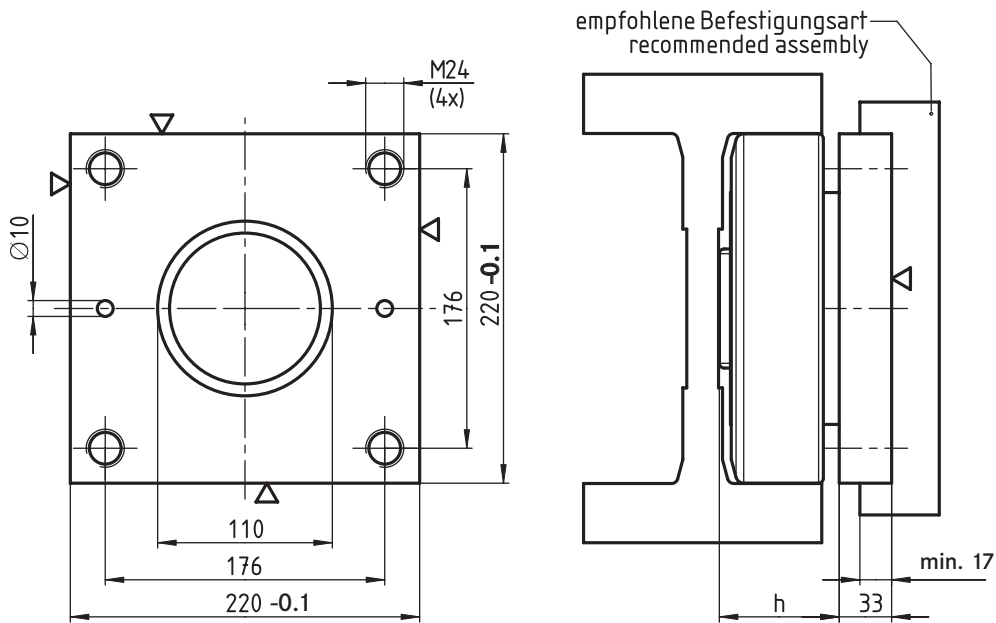

Typ Type	Rolle Bearing	Profil Profile	h h	Gewicht Weight	Distanzscheiben Washer
AP 91-Q	4.091	Standard 18	74,5-77,5	12,5	DS-91-0,5 DS-91-1,0

AP 92-Q

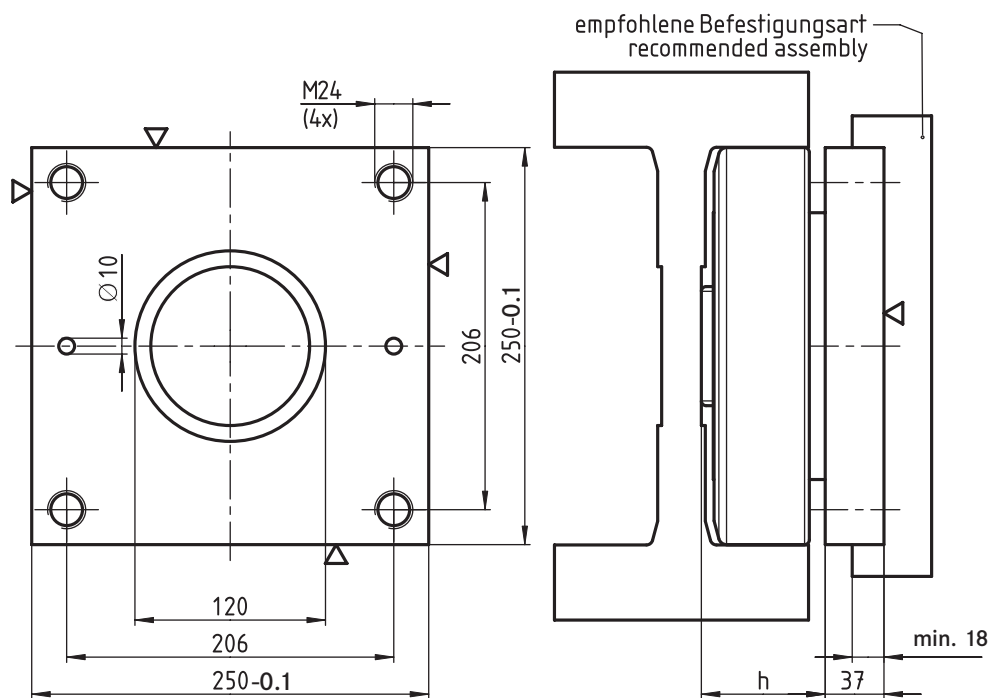

Typ Type	Rolle Bearing	Profil Profile	h h	Gewicht Weight	Distanzscheiben Washer
AP 92-Q	4.092	Standard 28	77-80	18,0	DS-92-0,5 DS-92-1,0

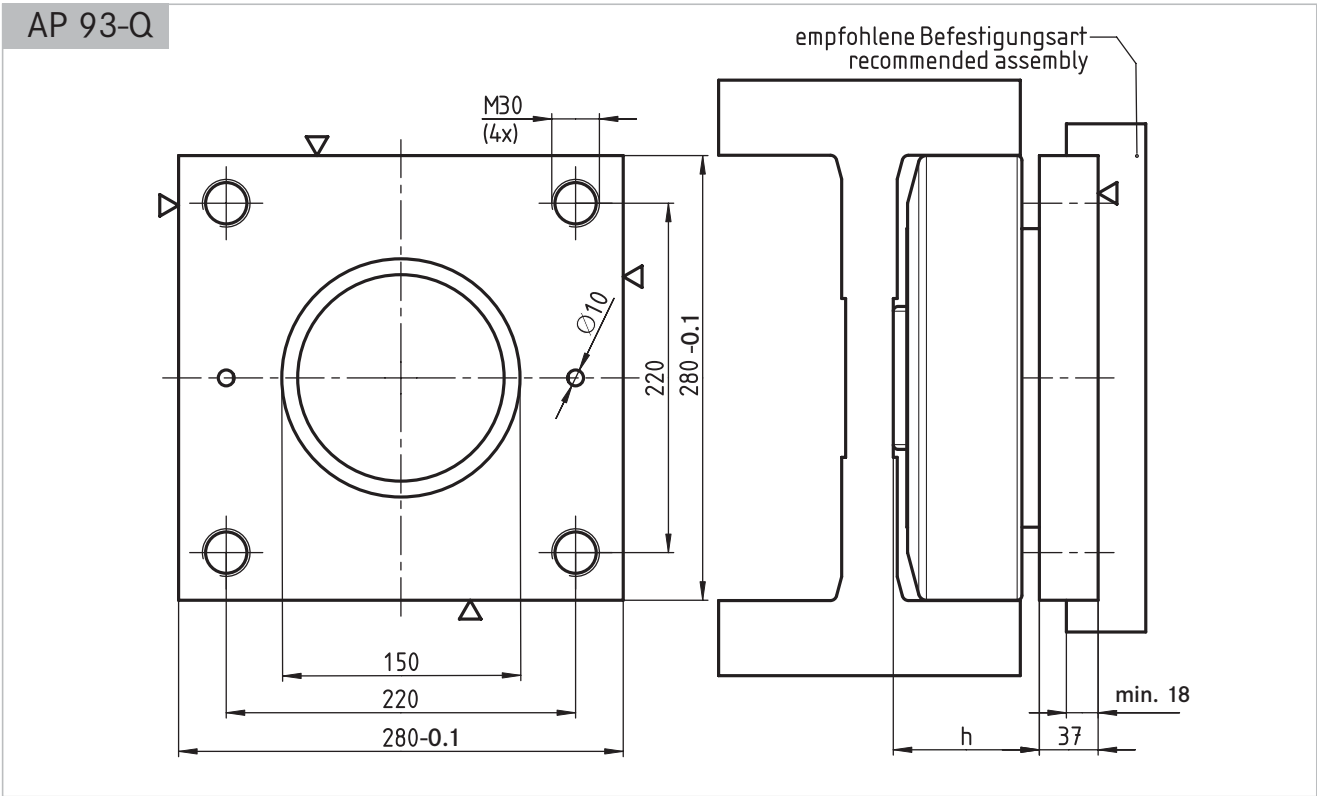

Typ Type	Rolle Bearing	Profil Profile	h h	Gewicht Weight	Distanzscheiben Washer
AP 93-Q	4.093	Standard 36 Standard 42	89,5-93,5	22,0	DS-93-0,5 DS-93-1,0